



CFM12S SERIES

12 WATT SINGLE OUTPUT AC-DC OPEN FRAME



Features

- * Universal Input 90~264VAC
- * High Efficiency up to 87%
- * Approved EN55032 Class B and CISPR/FCC Class B
- * Approved IEC62368-1, UL62368-1, EN62368-1
- * Meets EN60335-1
- * Continuous Short Circuit Protection
- * Over Voltage Protection
- * No Load Input Power < 75mW
- * Class II



Ordering information

CFM12SXXX - X

Blank: PCB mount

E: Encapsulated

T: WAFER

MODEL	Output Voltage	Output Current	Ripple (mV p-p) NOTE 1	Voltage Accuracy NOTE 2	Line Regulation NOTE 3	Load Regulation NOTE 4	% EFF. (typ.) NOTE 5
CFM12S050	5V	2A	100mV	±2%	±1%	±1%	80%
CFM12S090	9V	1.34A	100mV	±2%	±1%	±1%	85%
CFM12S120	12V	1.0A	120mV	±2%	±1%	±1%	85%
CFM12S150	15V	0.8A	150mV	±2%	±1%	±1%	85%
CFM12S240	24V	0.5A	240mV	±2%	±1%	±1%	87%

Specifications

INPUT SPECIFICATIONS:

Voltage 90~264Vac
 120~370Vdc
 Frequency 47 to 63Hz
 Inrush Current 50A max. @240Vac. Cold Start @25°C
 Leakage Current 0.25mA max. @ 264Vac
 Input Current 0.4A max.

OUTPUT SPECIFICATIONS:

Holdup Time 10ms typ. @115Vac
 Short Circuit Protection Hiccup Mode (Auto Recovery)
 Temperature Coefficient ±0.05% / °C
 Over Voltage Protection Hiccup Mode(Auto Recovery)
 Startup time <3.0s

GENERAL SPECIFICATIONS:

Isolation Voltage(Input to Output) 3000VAC:
 Operating Temperature..... -40°C~75°C (Derating from 50°C to 75°C)
 Storage Temperature -40°C~85°C
 Cooling Natural Convection
 Humidity 93% RH max. Non condensing
 Switching Frequency 65KHz Typical
 MTBF MIL-HDBK-217F, GB, 25°C/115VAC 870Khrs max.
 Altitude 5000m
 Dimensions 1.500x1.000x0.756 Inches (38.10x25.40x19.20mm)
 -E: 1.600x1.1x0.772 Inches (40.64x27.94x19.60 mm)
 -T: 2.150x1.000x0.689 Inches (54.61x25.40x17.50 mm)
 Weight 16g, (-E): 40g, (-T): 17g

CFM12S Series De-rating Curve

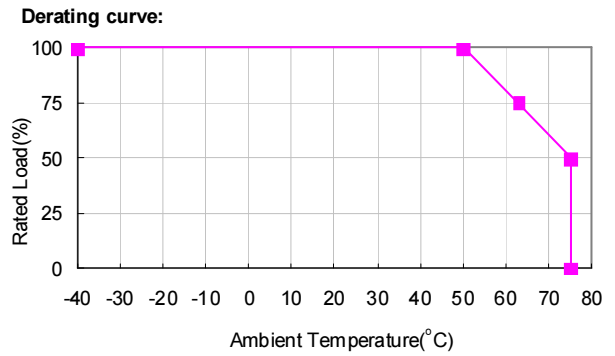

SAFETY AND EMISSION:

Emission and Immunity..... EN55032 Class B, EN55024, EN61204-3
 EN61000-3-2, -3, EN61000-6-1, 2, 3, 4
 47 CFR FCC Part 15 Subpart B (Class B)
 Safety IEC62368-1, UL62368-1, EN62368-1
 IEC60950-1, UL60950-1

NOTE:

1. Add a 0.1uF ceramic capacitor and a 10uF E.L. capacitor to output for ripple&noise measuring @20MHz BW.
2. Voltage accuracy is set of 100% rated load.
3. Line regulation is measured from high line to low line with full load.
4. Load regulation is measured from 10% to 100% full load.
5. Typical efficiency at 230Vc and full load at 25°C
6. T Version wafer with JST B3B-XH/B4B-XH and mate with JST housing XH series or equivalent.

Mechanical Specification

CFM12SXXX

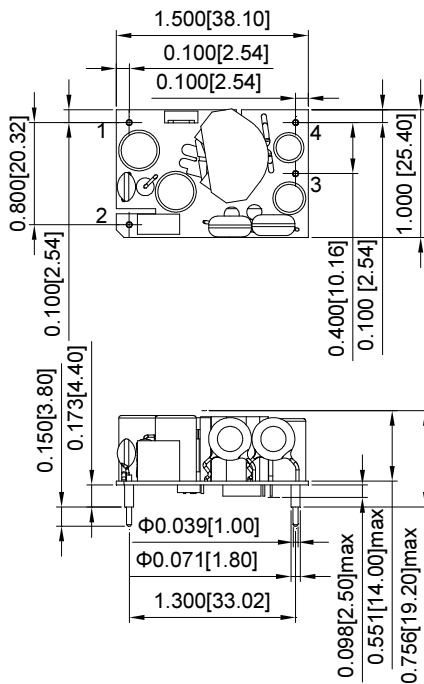

CFM12SXXX-E

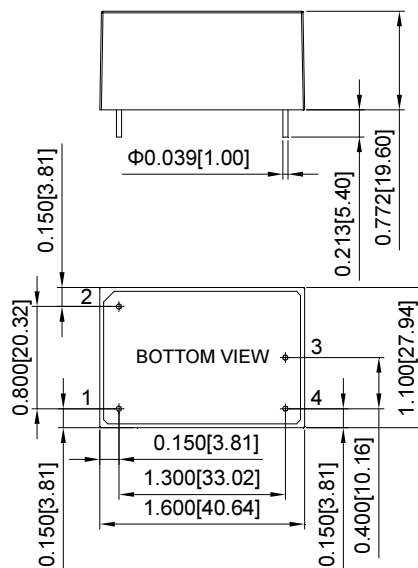

PIN CONNECTION

Pin	Function
1	ACN
2	ACL
3	-Vout
4	+Vout

All Dimensions are in inches[mm]
 Tolerance:Inches:X.XXX±0.02
 Millimeters:X.XX±0.5

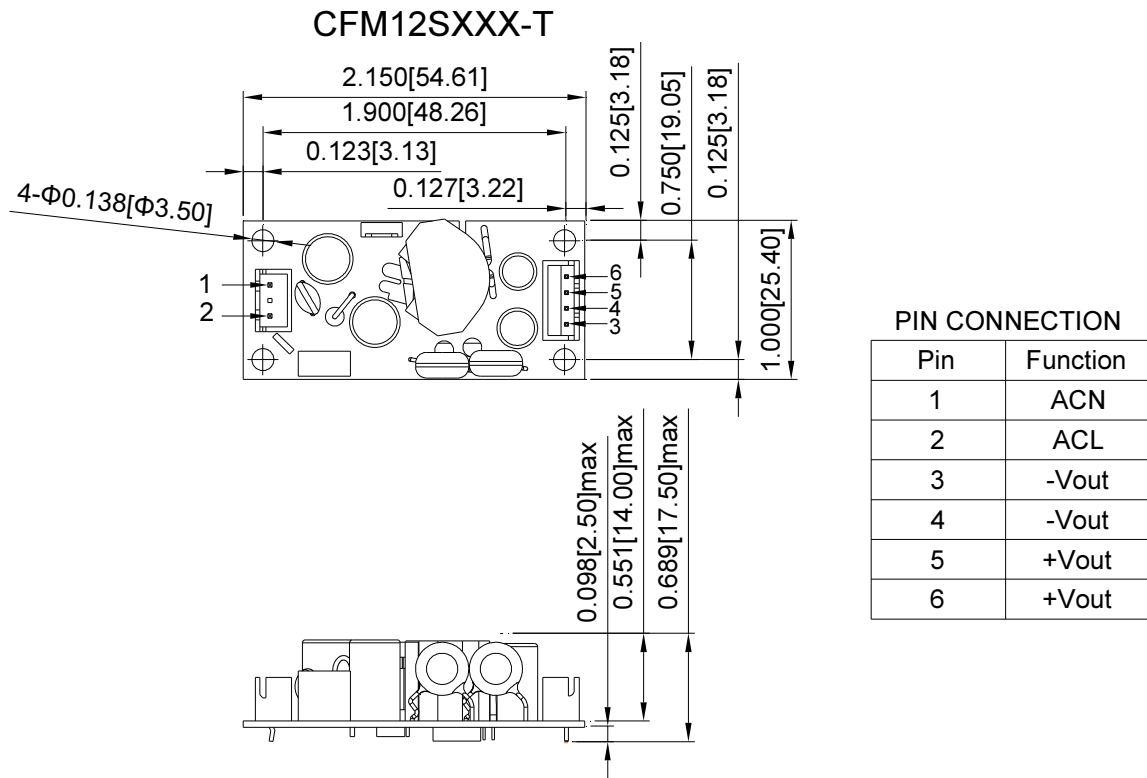
Mechanical Specification

Typical at 25°C, nominal line and 75% load, unless otherwise Specified