



**CHASSIS PLATFORMS**

**EMBEDDED COMPUTING  
PRODUCTS**



**SYSTEM ACCESSORIES**

**BACKPLANES**



**COMPONENTS**

**PICMG: ATCA Products and Services**

# Elma Electronic

## WHO IS ELMA ELECTRONIC

Founded in 1962, Elma is a leading global manufacturer and supplier of products used in integrated embedded platforms for military/aerospace, communications, medical imaging, and industrial applications. Based in Fremont, California and Wetzikon, Switzerland, the company has facilities and representatives in over 24 countries. Elma has a broad base of customers in diverse industries such as military and defense, telecommunications, industrial control, and medical electronics.

The Elma group of companies' products and services range from electromechanical components, to boards, to complete standard or custom system platforms. Elma constantly strives to provide products designed to be superior in quality, reliability, performance, and innovation. The focus is to leverage proven technology based on VITA (VME, VPX, and VXS), PICMG standard architectures (PCI, ATCA and MicroTCA) and rugged COTS based solutions.

The company offers fast, flexible response to customer needs and extensive practical knowledge in tailoring solutions to specific applications. The combined Elma Team has the knowledge and resources critical to address the increasing complexity and interplay between backplane, packaging, board level and software aspects of a successfully integrated System Solution. The addition of the ACT/Technico brand of products and services strengthens Elma's position as a vertically integrated supplier for Embedded Computing customers, while the Bustronic division provides unsurpassed high end backplane design expertise.

Elma's product line encompasses well over 16,000 parts, including system packaging and boards, enclosures, backplanes, cabinets, and other electro-mechanical components. Elma's quality level is reached through training of all employees and following of systematic procedures per ISO 9001 standards, to which Elma has been certified.

## WHY CHOOSE ELMA

**Flexibility** | Elma tailors solutions to individual applications to ensure fast and cost-effective results.

**Experience** | Extensive practical experience in packaging electronic systems is used to minimize the time taken to develop new customized solutions without compromising system performance or reliability.

**Compatibility** | Because the two key electromechanical components - enclosures and backplanes - are made in-house, Elma guarantees compatibility, consistency and reliability.

**Global Resources** | With manufacturing in Europe, Asia and the USA, customers benefit from local service backed by global resources.

## ELMA PRODUCT DIVISIONS

### Systems



### Embedded Computing Products



### Backplanes



### Enclosures & Components



### Cabinets



### Switches, Knobs & LEDs



---

## HOW ELMA DOES IT - CORE CAPABILITIES

The company supplies a first class offering of products for standard and rugged COTS electronics packaging and sub-systems integration: boards, chassis, backplanes, mechanical components, cabinets, and LED/switches for a wide variety of applications worldwide. The ACT/Technico branded products and services enable Elma to be a leading supplier of integrated embedded boards and sub-systems built on open standards platforms, including Single Board Computers, mass storage and RAID products, I/O and networking solutions, RTOS, Linux or Windows, and device drivers.

System architecture, hardware, and software design services are offered to quickly deliver complete solutions and expedite time to market. We take true COTS products, such as single board computers and PMCs, then enhance and qualify them to meet your rugged requirements.

This extensive range of products and services gives Elma Electronic Inc. a unique ability to complete entire projects from initial system architecture through specification, design, manufacturing and test.

Elma has a professional sales team committed to the value added sale. Our sales staff and application engineers are able to match requirements to the application and recommend semi or full custom solutions when appropriate. Our staff of experienced electrical, software, mechanical and system engineers combine to provide state of the art solutions designed to meet our customers' specifications. We support those products long after shipment with warranty coverage and complete documentation packages.

In house manufacturing capability rounds out our ability to integrate the products and designs into a complete, shippable solution. Our Quality department rigorously maintains our corporate commitment to ship products that are built with quality workmanship.

Elma is capable of quickly turning projects from initial system architecture through to specification, design, manufacturing and test. We also work with you to manage the entire project including EOL issues, spares inventory and lifecycle management.

## TECHNICAL CAPABILITIES

- Standard and rugged COTS integration and test expertise
- System platform architecture design and development
- Hardware and software selection
- Chassis platform design and selection
- Embedded and COTS system integration
- High performance cable assemblies
- Manufacturing
- Run rates from 10's to low 1000's
- Project management
- Full support for the project, single point of contact
- Software installation
- Bootable device drivers included as needed
- Device driver development
- Functionally tested in hardware matching target system
- Testing
- Factory test software
- System level/payload testing  
SBCs, I/O, storage, operating system
- Unit level environmental testing  
ESS, NEBS, MIL-STDs 167, 810, 901D
- Regulatory compliance testing CE, UL, FCC

## CUSTOM SOLUTIONS

Customization is the standard at Elma Electronic. With an extensive offering of modular products as a foundation, Elma is able to leverage existing solutions and proven design concepts to meet any custom application. This approach ensures that Elma will provide a quality, compliant solution with significantly reduced lead time, cost and risk. Elma leads the industry in modifying standard PICMG based backplanes and chassis to meet customers' exact needs.

# Table of Contents

<b>PICMG History &amp; Overview</b>	4
<b>AdvancedTCA System Chassis Platforms</b>	
Overview	5
AdvancedTCA Order Key	8
2U - 19" Rackmount (DC)	9
3U - 19" Rackmount (AC)	11
4U - 19" Rackmount (DC)	13
5U - 19" Rackmount (AC)	15
5U - 19" Rackmount (DC)	17
6U - 19" Rackmount (AC)	19
13U - 19" Rackmount (DC)	21
<b>Embedded Computing Products</b>	
Overview	23
Storage	23
Single Board Computers / Blades	24
Networking	24
I/O Products	24
AppliPaks / Processor Brick	25
SystemPaks	25
Subsystems	26
Rugged Products	26
<b>System Accessories</b>	
Bridges - cPCI	27
SysMon Online Pro	28
Test Extender Boards	104
Load Boards	105
Rear Extender Boards	106
ATCA Probe Card	107
Air Block Modules (Slot Bypass Board)	110
<b>Backplanes</b>	
ATCA Backplanes	117
<b>Components</b>	
General Accessories	133-136

## PICMG History and Overview

CompactPCI (cPCI) was formed in the late 1990's to offer a ruggedized, Eurocard-based form factor around PCI. The specification is based on the 2mm connector standard and the IEEE 1101.10/11 mechanicals. PCIbus was a proven bus with an enormous installed base in different market segments like telecom, industrial automation, etc. The CompactPCI architecture could also leverage off the lower cost, widely available PCI silicon and the omnipresent WinTel (Windows/Intel) architecture. A 64-bit implementation could boast a data transfer rate of 533Mbytes/sec. Like the way VITA promoted VME successfully, cPCI was effectively promoted by a group of PCI manufacturers under PICMG. PICMG released a series of specifications in the late nineties that addressed critical requirements in the Telecommunications industry like Hot swap and five nines availability (99.999). PICMG 2.1 (Hotswap), PICMG 2.5 (H110 Telephony bus), PICMG 2.7 (Dual system slot) and PICMG 2.9 (System management bus) were some of the specifications that made using cPCI bus a compelling reason for new products catering to computer telephony, VoIP and a myriad other applications.

With a soaring demand for more speed and bandwidth fueled by the Internet boom, cPCI became extremely popular with its open standard that helped speed the "time to market" for new entrants in the telecom arena. The Eurocard form factors of 6U by 160mm for front line cards and 6U x 80mm for rear transition cards was tailor made for platform providers to develop rackmount equipment that met the NEBS criteria for 300mm depth as well as cable management – important considerations for Central Office applications.

Eventually, the slot limitations of CompactPCI and the bottlenecks to higher data transfer rates (a must for I/O intensive applications) posed by bus based architecture prompted the foray into high speed serial buses and Switched Fabric architectures. Specifications like the PICMG 2.16 for packet switching backplanes (cPSB) and PICMG 2.17 (aka Star Fabric) employed a fabric for the dataplane and a traditional bus like cPCI for the control plane. The use of a reliable bus like cPCI mitigated the risks associated with fabrics while leveraging their higher performance levels for high-end applications. Switch-fabric interconnection is also preferable for high availability applications due to their self-healing features.

In late 2001, PICMG formed a committee to develop a new series of specifications aimed at the next generation of Telecom requirements. The 3.X series was renamed as Advanced Telecom Computing Architecture (or ATCA) and an 8U Eurocard was chosen as the form factor of choice. The specification is geared towards the telco carrier grade market. Utilizing Dual Star, Dual Dual Star, and Mesh switched fabric topologies, the spec will be able to handle the massive bandwidth requirements, High Availability (99.999% uptime), and Quality of Service issues demanded by the industry. The form factor uses an 8U x 280mm card size plugging into a backplane spaced at 1.2". The larger cards allow more space for more components, while the wider spacing between slots allows for taller components. In addition, the backplane allows for 48VDC input from an external source to be distributed to the individual slot cards. The slot-to-slot bandwidth is approximately 7500 Mbytes/sec (assuming 2.5 Gbps per pair)

In 2006, the MicroTCA.0 committee was formed to develop a smaller and lower cost "ATCA-Lite" alternative. As ATCA provides a carrier platform for AMCs (Advanced Mezzanine Cards), the thought was to have these AMCs plug directly into a backplane instead. The MicroTCA system allows single or redundant virtual carriers (MCHs) to provide power management, platform management and fabric connections to greater numbers of modules than a single physical carrier card could support in a classic ATCA application. MicroTCA systems have options for single or double modules and full, mid, or compact sizes. AdvancedMC modules are targeted for such modular applications as storage arrays, firewalls, blade servers, and more. Each module may dissipate between 20 and 60W each and the platform management scheme is designed to support applications from 99.99% to 99.999% availability. The slot-to-slot bandwidth is approximately 5000 Mbytes/sec (assuming 2.5 Gbps per pair).

### PICMG STANDARDS

**PICMG 2.0 R3.0** - CompactPCI

**PICMG 2.1 R2.0** - CompactPCI Hot Swap

**PICMG 2.2** - VME64x Bus Pin Assignments on CompactPCI

**PICMG 2.3** - PMC I/O Pin Assignments on CompactPCI

**PICMG 2.4** - IP I/O Pin Assignments on CompactPCI

**PICMG 2.5** - CompactPCI Computer Telephony Specification

**PICMG 2.7** - Dual CompactPCI Backplanes

**PICMG 2.9** - Secondary System Management Bus for CompactPCI

**PICMG 2.11** - Power Interface

**PICMG 2.12 R1.0** - CompactPCI Software Interoperability

**PICMG 2.12 R2.0** - IP I/O Pin Assignments on CompactPCI

**PICMG 2.14** - CompactPCI Multicomputing

**PICMG 2.15** - PCI Telecom Mezzanine Card Specification (PTMC)

**PICMG 2.15** - Revision 1.0 ECN 001

**PICMG 2.16** - IP Backplane for CompactPCI

**PICMG 2.17** - Switched PCI-PCI Bridging for CompactPCI

**PICMG 2.20** - Serial Mesh Interconnect

**PICMG 3.0** - Advanced Telecom Computing Architecture (ATCA)

**MicroTCA.0** - MicroTCA



**Advanced TCA®**

**μTCA™**



# AdvancedTCA System Platforms, Overview



## DESCRIPTION

AdvancedTCA is the trademark name of the architecture being described in the PICMG 3.0 specification. This specification is intended to define open architecture modular computing components that can be quickly integrated to deploy high performance services solutions. The specification is focused on the definition of an architecture that can:



## ADVANTAGES:

- Superior thermal performance
- Modular design enables faster time to market
- Designed to meet NEBS
- Wide range of chassis configurations
- Proven design concept reduces program risk (time and cost)
- Choice of backplane fabric topologies (star, dual star, mesh full & replicated)
- 40 Gbs backplane options



## FEATURES:

- Compliant to PICMG 3.0
- 2U - 6U horizontal configurations
- 13U vertical configurations
- 48 VDC and 90 - 235 VAC options
- Up to 300W slot cooling
- N+1 redundant power entry modules (PEMs)
- Optional, redundant shelf manager
- Designed to meet FCC & NEBS EMC requirements
- Application to edge core, transport and data center
- Application to wireless, wireline, and optical network elements
- Processors: digital signal processors (DSPs), network processors (NPs), storage, and input/output (I/O)

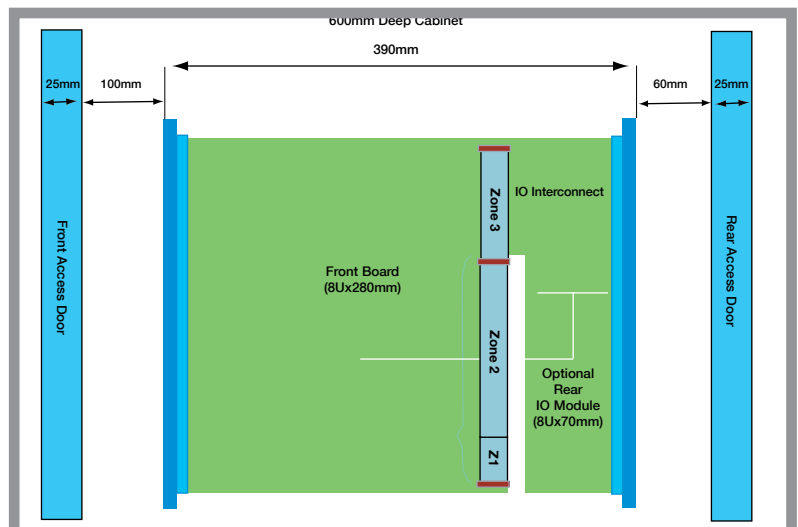



3U • 19" RACKMOUNT • AC

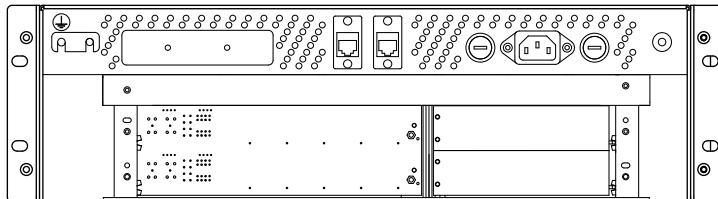
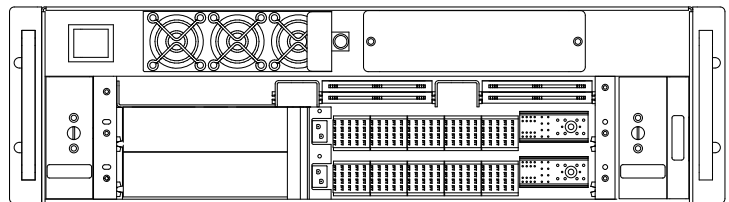
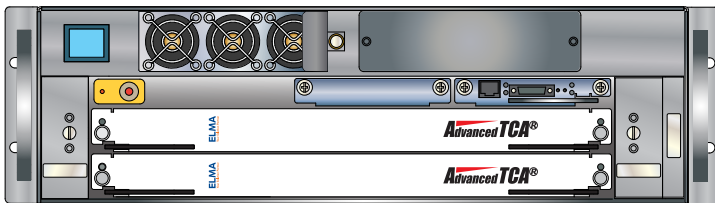

# AdvancedTCA System Platforms, Overview

## THERMAL SIMULATIONS

Elma's Thermal Simulation can be extremely helpful in coming up with an optimal ATCA chassis cooling solution. Elma can simulate specifically how your boards interact with the chassis in regards to the cooling. After modeling your card, Elma's designers can verify the cooling and make sure the hotter components of the card are placed in cooler parts of the chassis. If the per slot loading is provided, thermal simulation could be performed where baffles or extra fans could be added to ensure proper cooling for all boards.

Using CFD-based (Computation Fluid Dynamics) thermal modeling software like FlowTherm, Elma can change the intake and exhaust areas, change fans and fan configuration, add and optimize baffling and monitor the temperature at critical locations before fabricating and testing a chassis. Simulation can help determine the proper fans to use in order to ensure proper chassis cooling as well as keeping the audible noise level at a minimum. Locating hot spots in the chassis, the designer can simulate options to rectify the situation. For example, a baffle can be placed in a particular area to direct airflow, or changing a fan's position to increase or decrease the air plenum. A different type of fan or blower can also be used to improve the results. Simulation can also help maximize the usefulness of the shelf managers. Thermal analysis can show how a shelf manager can tie or group fans together to optimize airflow when it senses a problem. It can also help determine the ideal sequence in timing solution for shutting down cards, which signals to send, and when it is absolutely necessary to shut down the entire system. Contact Elma at (510) 656-3400 for more information on our Thermal Simulation services.

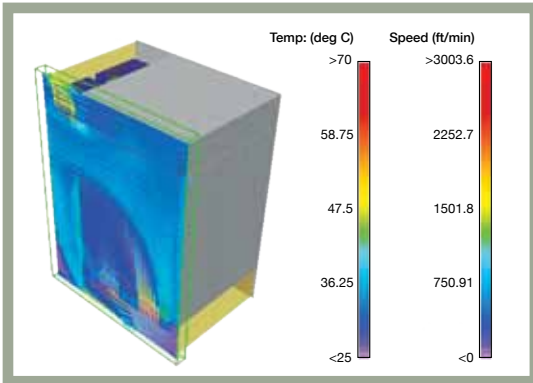

New 12U ATCA with TRM r5

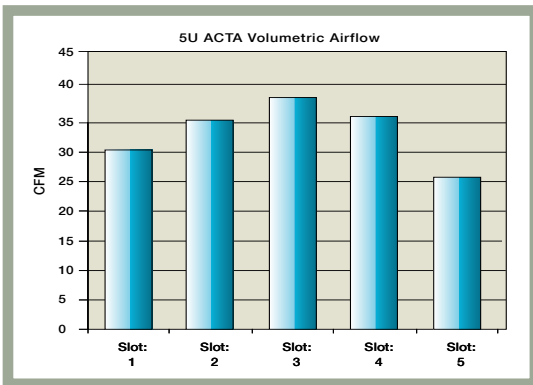

5U ATCA Volumetric Airflow

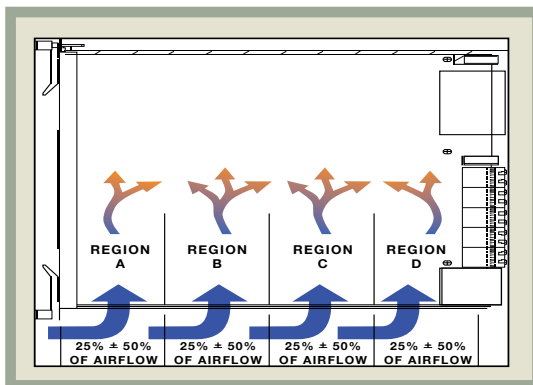

13U Even Airflow Distribution

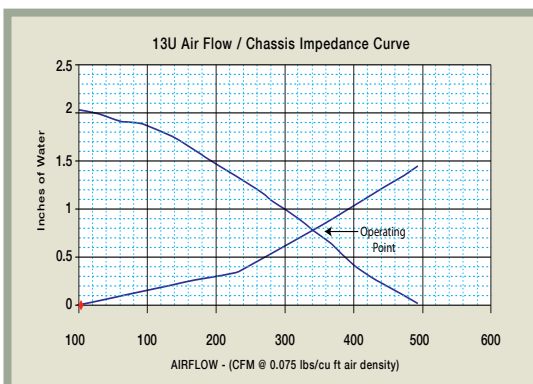

13U Airflow / Chasis Impedance Curve



# AdvancedTCA Order Key

11A 

- NUMBER OF SLOTS BP
  - 00-21: Single BP; AY-YA: Split
  - 02 = 2 slot
  - 05 = 5 slot
  - 06 = 6 slot
  - 14 = 14 slot
- BP BARE BOARD
  - E = 1 x SM
  - F = 2 x SM (Bussed IPMB)
  - G = 2 x SM (Radial IPMB)
  - Z = Custom
- FABRIC ARCHITECTURE
  - F = Star
  - G = Dual Star
  - H = Mesh
  - J = Replicated Mesh
  - Z = Custom
- COOLING
  - A = 1 x Tray (plug in)
  - B = 2 x Tray (plug in)
  - C = 3 x Tray (Plug in)
  - Z = Custom
- HEIGHT
  - 1 = 1U
  - 2 = 2U
  - 4 = 4U
  - 5 = 5U
  - C = 12U
  - D = 13U
- WIDTH
  - 8 = 84 T
  - E = ETSI
- REAR I/O
  - N = No
  - Y = Yes
- DEPTH
  - 2 = 200 - 299mm
  - 3 = 300 - 399mm
  - 4 = 400 - 499mm
- CARD ORIENTATION
  - V = Vertical
  - H = Horizontal
- PSU INPUT
  - C = 90 - 230VAC (Fixed)
  - G = 90 - 230VAC (Plug-in)
  - H = 48VDC
  - M = Dual 48VDC
  - N = Quad 48VDC
  - P = 90-230VAC(2 x HS, N+1)
  - Q = 90-230VAC(3 x HS, N+1)
  - X = No PSU
- PSU OUTPUT  
(NOT ALL PSU COMBINATIONS AVAILABLE)
  - 2 = 200 - 299 watts
  - 3 = 300 - 399 watts
  - 4 = 400 - 499 watts
  - 5 = 500 - 599 watts
  - 6 = 600 - 699 watts
  - 8 = 800 - 899 watts
  - A = 1000 - 1199 watts
  - B = 1200 - 1299 watts
  - C = 1600 - 1799 watts
  - D = 1800 - 1999 watts
  - E = 2000 - 2199 watts
  - F = 2200 - 2399 watts
  - G = 2400 - 2599 watts
  - H = 2600 - 2799 watts
  - X = Not Installed
- SHELF MANAGER (Installed)
  - R = 1 x Fixed
  - S = 1 x Plug in
  - D = 2 x Plug in
  - X = Not Installed

# AdvancedTCA, 2U - 19" Rackmount DC



**FEATURES:**

- 2U high
- Holds 2 ATCA cards
- 2 slot Replicated mesh backplane
- Rear I/O
- Dual Shelf Managers
- Dual removable fan trays
- 250 watts/slot cooling
- Dual 48VDC input
- NEBS compliant removable air filter

## SCOPE OF SUPPLY

High quality 19" rackmount chassis platform consisting of pre-galvanized steel enclosures painted black: high performance PICMG 3.0 backplane, power supply, PEM (DC); cooling system and DC power components. Assembled, wired and tested prior to shipment.

## ORDERING INFORMATION

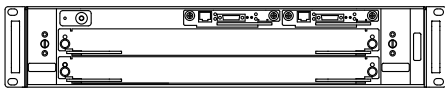

Description	Order Number
<ul style="list-style-type: none"> <li>■ 2U H x 19" W x 385mm D</li> <li>■ Holds two, 8U x 280mm blades</li> <li>■ Redundant plug-in fan trays</li> <li>■ 2 Slot Replicated Mesh backplane</li> <li>■ Provision for dual Shelf Manager (not installed)</li> <li>■ Dual 48 VDC PEM inputs</li> </ul>	<p>11A02FJB28Y3HMXX</p>

## LINE DRAWINGS

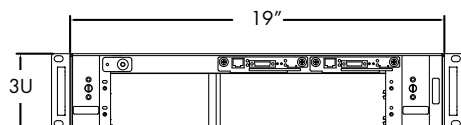

Front View

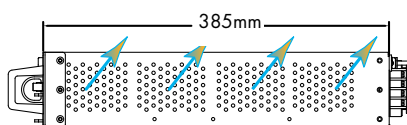

Air Flow - Side to Side

Side View

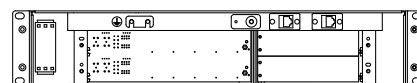

Rear View

## ENVIRONMENTAL

	Operating	Storage / Transit
<b>Temperature:</b>	0°C to +50°C	-20°C to +70°C
<b>Altitude:</b>	6000 ft. (1,829m)	50,000 ft. (15,240m)
<b>Humidity:</b>	5% to 95% Non condensing	5% to 95% Non condensing
<b>Shock:</b>	10 Gs @ 11ms	15 Gs @ 11ms (per ASTM 0775)
<b>Vibration:</b>	1.0 Gs @ 10 to 330 Hz	1.2 Gs @ 5 to 330 Hz
<b>Agencies:</b>	Designed to meet UL 1950, FCC Class A or B, CE	

## CUSTOM CONFIGURATIONS

1 1A      2 8  3 H

- NUMBER OF SLOTS BP  
00-21: Single BP; AY-YA: Split  
02 = 2 slot

- BP BARE BOARD  
E = 1 x SM  
F = 2 x SM (Bussed IPMB)  
G = 2 x SM (Radial IPMB)  
Z = Custom

- FABRIC ARCHITECTURE  
G = Dual Star  
H = Mesh  
J = Replicated Mesh  
Z = Custom

- COOLING  
A = 1 x Tray (plug in)  
B = 2 x Tray (plug in)  
Z = Custom

- HEIGHT  
2 = 2U

- WIDTH  
8 = 84 T

- REAR I/O  
N = No  
Y = Yes

- DEPTH  
3 = 300 - 399mm

- CARD ORIENTATION  
H = Horizontal

- PSU INPUT  
C = 90 - 230VAC (Fixed)  
H = 48VDC  
M = Dual 48VDC  
X = No PSU

- PSU OUTPUT  
(NOT ALL PSU COMBINATIONS AVAILABLE)  
2 = 200 - 299 watts  
3 = 300 - 399 watts  
4 = 400 - 499 watts  
5 = 500 - 599 watts  
X = Not Installed

- SHELF MANAGER (Installed)  
R = 1 x Fixed  
S = 1 x Plug in  
D = 2 x Plug in  
X = Not Installed

\*NOTE: Elma's radial IPMB signals are radially connected across the backplane to the Shelf Manager Carrier Card. The Shmm 500 IPM module resides on the carrier card where these connections are bussed.

# AdvancedTCA, 3U - 19" Rackmount

## AC



### FEATURES:

- 3U High 19" Rack mount
- Depth 16" (407mm)
- 2 Slot ATCA backplane
- Two blade slots (8Ux280mm)
- Two RTM board slots (8Ux80mm)
- Dual shelf manager capability
- Dual fan trays, push/pull configuration
- Air filter tray
- Dual plug-in 1200W Power supply (optional)
- 2 Slot Replicated mesh backplane

## SCOPE OF SUPPLY

High quality 19" rackmount chassis platform consisting of pre-galvanized steel enclosures painted black: high performance PICMG 3.0 backplane, power supply (AC), cooling system and AC/DC power components. Assembled, wired and tested prior to shipment.

## ORDERING INFORMATION

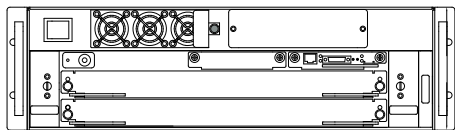

Description	Order Number
<ul style="list-style-type: none"> <li>■ 3U H x 19" W x 403mm D</li> <li>■ Holds two, 8U x 280mm blades</li> <li>■ Holds two, 8U x 80mm, Rear I/O</li> <li>■ Redundant plug-in fan trays</li> <li>■ 2 slot replicated mesh backplane</li> <li>■ Provision for dual Shelf Manager (not installed)</li> <li>■ 1 x 1200w, AC input PSU ( n+1 optional)</li> </ul>	11A02FJB38Y4HGBX

## LINE DRAWINGS

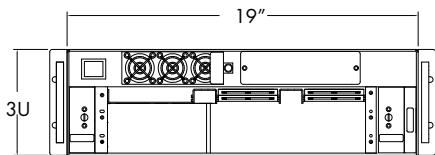

Front View

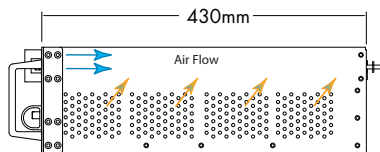

Side View

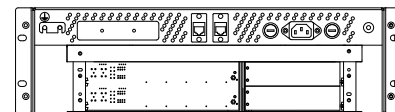

Rear View

## ENVIRONMENTAL

	Operating	Storage / Transit
<b>Temperature:</b>	0°C to +50°C	-20°C to +70°C
<b>Altitude:</b>	6000 ft. (1,829m)	50,000 ft. (15,240m)
<b>Humidity:</b>	5% to 95% Non condensing	5% to 95% Non condensing
<b>Shock:</b>	10 Gs @ 11ms	15 Gs @ 11ms (per ASTM 0775)
<b>Vibration:</b>	1.0 Gs @ 10 to 330 Hz	1.2 Gs @ 5 to 330 Hz
<b>Agencies:</b>	Designed to meet UL 1950, FCC Class A or B, CE	

## CUSTOM CONFIGURATIONS

1 1A      3 8 Y 4 H  B

- NUMBER OF SLOTS BP
  - 00-21: Single BP; AY-YA: Split
  - 02 = 2 slot
  - 05 = 5 slot
  - 06 = 6 slot
  - 14 = 14 slot
- BP BARE BOARD
  - E = 1 x SM
  - F = 2 x SM (Bussed IPMB)
  - G = 2 x SM (Radial IPMB)
  - Z = Custom
- FABRIC ARCHITECTURE
  - F = Star
  - G = Dual Star
  - H = Mesh
  - J = Replicated Mesh
  - Z = Custom
- COOLING
  - A = 1 x Tray (plug in)
  - B = 2 x Tray (plug in)
  - C = 3 x Tray (Plug in)
  - Z = Custom
- HEIGHT
  - 1 = 1U
  - 2 = 2U
  - 4 = 4U
  - 5 = 5U
  - C = 12U
  - D = 13U
- WIDTH
  - 8 = 84 T
  - E = ETSI
- REAR I/O
  - N = No
  - Y = Yes
- DEPTH
  - 2 = 200 - 299mm
  - 3 = 300 - 399mm
  - 4 = 400 - 499mm
- CARD ORIENTATION
  - V = Vertical
  - H = Horizontal
- PSU INPUT
  - C = 90 - 230VAC (Fixed)
  - G = 90 - 230VAC (Plug-in)
  - H = 48VDC
  - M = Dual 48VDC
  - N = Quad 48VDC
  - P = 90-230VAC(2 x HS, N+1)
  - Q = 90-230VAC(3 x HS, N+1)
  - X = No PSU
- PSU OUTPUT  
(NOT ALL PSU COMBINATIONS AVAILABLE)
  - 2 = 200 - 299 watts
  - 3 = 300 - 399 watts
  - 4 = 400 - 499 watts
  - 5 = 500 - 599 watts
  - 6 = 600 - 699 watts
  - 8 = 800 - 899 watts
  - A = 1000 - 1199 watts
  - B = 1200 - 1299 watts
  - C = 1600 - 1799 watts
  - D = 1800 - 1999 watts
  - E = 2000 - 2199 watts
  - F = 2200 - 2399 watts
  - G = 2400 - 2599 watts
  - H = 2600 - 2799 watts
  - X = Not Installed
- SHELF MANAGER (Installed)
  - R = 1 x Fixed
  - S = 1 x Plug in
  - D = 2 x Plug in
  - X = Not Installed

\*NOTE: Elma's radial IPMB signals are radially connected across the backplane to the Shelf Manager Carrier Card. The Shmm 500 IPM module resides on the carrier card where these connections are bussed.



# AdvancedTCA, 4U - 19" Rackmount

DC



## FEATURES:

- Compliant to PICMG 3.0 specification
- 4U x 444mm x 385mm (H x W x D)
- 5 slot replicated mesh backplane
- Cooling side to side ( 2 x 170 CFM fans)
- Plug removable fan tray
- Dual 48VDC input terminals
- Front and rear ESD jack
- Shelf manager optional
- Customization available

## SCOPE OF SUPPLY

High quality 19" rackmount chassis platform consisting of pre-galvanized steel enclosures painted black: high performance PICMG 3.0 backplane, power supply, PEM (DC); cooling system and DC power components. Assembled, wired and tested prior to shipment.

## ORDERING INFORMATION

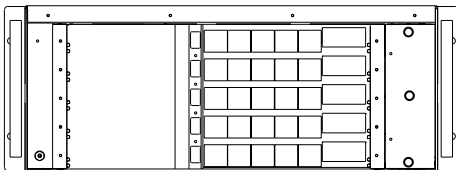

Description	Order Number
<ul style="list-style-type: none"> <li>■ 4U H x 19" W x 385mm D</li> <li>■ Holds 5, 8U x 280mm blades</li> <li>■ Holds 5, 8U x 70mm, rear I/O</li> <li>■ 5 Slot Replicated Mesh backplane</li> <li>■ 2 x 170 CFM Fans</li> <li>■ Shelf Manager not installed</li> <li>■ Dual 48VDC input</li> </ul>	11A05GJA48Y3HMXX

## LINE DRAWINGS

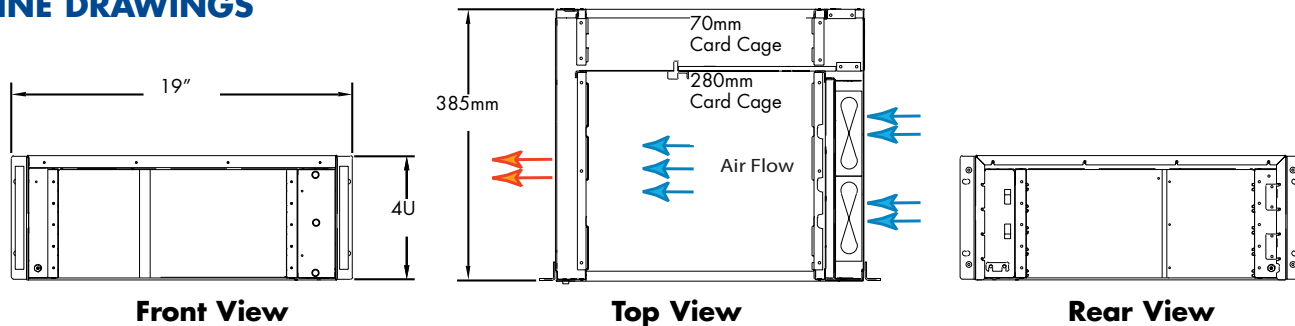

## ENVIRONMENTAL

	Operating	Storage / Transit
<b>Temperature:</b>	0°C to +50°C	-20°C to +70°C
<b>Altitude:</b>	6000 ft. (1,829m)	50,000 ft. (15,240m)
<b>Humidity:</b>	5% to 95% Non condensing	5% to 95% Non condensing
<b>Shock:</b>	10 Gs @ 11ms	15 Gs @ 11ms (per ASTM 0775)
<b>Vibration:</b>	1.0 Gs @ 10 to 330 Hz	1.2 Gs @ 5 to 330 Hz
<b>Agencies:</b>	Designed to meet UL 1950, FCC Class A or B, CE	

## CUSTOM CONFIGURATIONS

1 1A      4 8  3 H

- NUMBER OF SLOTS BP  
00-21: Single BP; AY-YA: Split  
05 = 5 slot
- BP BARE BOARD  
E = 1 x SM  
F = 2 x SM (Bussed IPMB)  
G = 2 x SM (Radial IPMB)  
Z = Custom
- FABRIC ARCHITECTURE  
G = G = Dual Star  
H = H = Mesh  
J = J = Replicated Mesh  
Z = Custom
- COOLING  
A = A = 1 x Tray (plug in)  
B = B = 2 x Tray (plug in)  
Z = Custom
- HEIGHT  
4 = 4U
- WIDTH  
8 = 84 T
- REAR I/O  
N = No  
Y = Yes
- DEPTH  
3 = 300 - 399mm
- CARD ORIENTATION  
H = Horizontal
- PSU INPUT  
H = 48VDC  
M = Dual 48VDC  
X = No PSU
- PSU OUTPUT  
(NOT ALL PSU COMBINATIONS AVAILABLE)  
X = Not Installed  
Y = Other
- SHELF MANAGER (Installed)  
R = 1 x Fixed  
S = 1 x Plug in  
D = 2 x Plug in  
X = Not Installed

\*NOTE: Elma's radial IPMB signals are radially connected across the backplane to the Shelf Manager Carrier Card. The Shmm 500 IPM module resides on the carrier card where these connections are bussed.

# AdvancedTCA, 5U - 19" Rackmount

## AC



### FEATURES:

- 5U high
- Holds 5 ATCA blades
- 5 slot replicated mesh backplane
- RTM (with cooling)
- Dual Shelf Managers
- Dual removable fan trays
- 250 watts/slot cooling
- 1200 Watt, AC input PSU (N+1 optional)
- NEBS compliant removable air filter

### SCOPE OF SUPPLY

High quality 19" rackmount chassis platform consisting of pre-galvanized steel enclosures painted black: high performance PICMG 3.0 backplane, power supply (AC); cooling system and AC/DC power components. Assembled, wired and tested prior to shipment.

### ORDERING INFORMATION

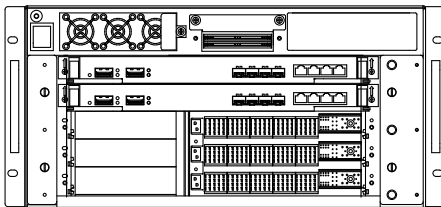

Description	Order Number
<ul style="list-style-type: none"> <li>■ 5UH x 19" W x 400mm D</li> <li>■ Holds 5, 8U x 280mm blades</li> <li>■ Holds 5, 8U x 80mm cards, rear I/O</li> <li>■ Redundant plug-in fan tray</li> <li>■ 5 slot replicated mesh backplane</li> <li>■ Provision for dual Shelf Manager (not installed)</li> <li>■ 1 x1200w, AC input PSU, (N+1 optional)</li> </ul>	11A05FJB58Y4HGBX

## LINE DRAWINGS

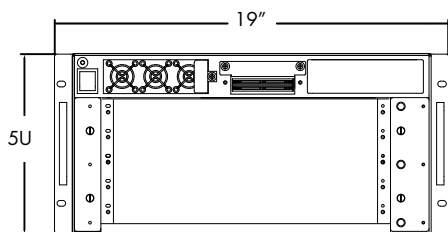

Front View

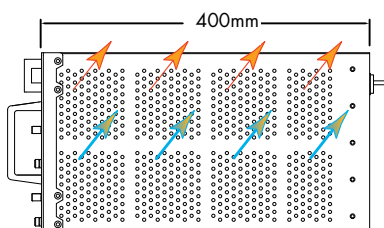

Air Flow - Side to Side

Side View

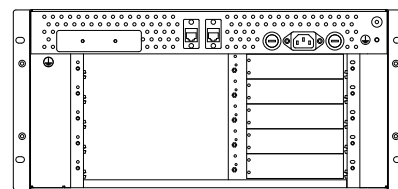

Rear View

## ENVIRONMENTAL

	Operating	Storage / Transit
<b>Temperature:</b>	0°C to +50°C	-20°C to +70°C
<b>Altitude:</b>	6000 ft. (1,829m)	50,000 ft. (15,240m)
<b>Humidity:</b>	5% to 95% Non condensing	5% to 95% Non condensing
<b>Shock:</b>	10 Gs @ 11ms	15 Gs @ 11ms (per ASTM 0775)
<b>Vibration:</b>	1.0 Gs @ 10 to 330 Hz	1.2 Gs @ 5 to 330 Hz
<b>Agencies:</b>	Designed to meet UL 1950, FCC Class A or B, CE	

## CUSTOM CONFIGURATIONS

1 1A      5 8  3 H

NUMBER OF SLOTS BP  
00-21: Single BP; AY-YA: Split  
05 = 5 slot

BP BARE BOARD  
F = 2 x SM (Bussed IPMB)  
G = 2 x SM (Radial IPMB)  
Z = Custom

FABRIC ARCHITECTURE  
G = Dual Star  
H = Mesh  
J = Replicated Mesh  
Z = Custom

COOLING  
A = 1 x Tray (plug in)  
B = 2 x Tray (plug in)  
Z = Custom

HEIGHT  
5 = 5U

WIDTH  
8 = 84 T

REAR I/O  
N = No  
Y = Yes

DEPTH  
4 = 400 - 499mm

CARD ORIENTATION  
H = Horizontal

PSU INPUT  
C = 90 - 230VAC (Fixed)  
G = 90 - 230VAC (Plug-in)  
H = 48VDC  
M = Dual 48VDC  
P = 90-230VAC(2 x HS, N+1)  
X = No PSU

PSU OUTPUT  
(NOT ALL PSU COMBINATIONS AVAILABLE)  
2 = 200 - 299 watts  
3 = 300 - 399 watts  
4 = 400 - 499 watts  
5 = 500 - 599 watts  
6 = 600 - 699 watts  
8 = 800 - 899 watts  
A = 1000 - 1199 watts  
B = 1200 watt  
X = Not Installed

SHELF MANAGER (Installed)  
R = 1 x Fixed  
S = 1 x Plug in  
D = 2 x Plug in  
X = Not Installed

\*NOTE: Elma's radial IPMB signals are radially connected across the backplane to the Shelf Manager Carrier Card. The Shmm 500 IPM module resides on the carrier card where these connections are bussed.

# AdvancedTCA, 5U - 19" Rackmount DC



## FEATURES:

- 5U high
- Holds 6 ATCA cards
- 6 slot replicated mesh backplane
- RTM (with cooling)
- Dual Shelf Managers
- Dual removable fan trays
- 250 watts/slot cooling
- Dual 48VDC input
- NEBS compliant removable air filter

## SCOPE OF SUPPLY

High quality 19" rackmount chassis platform consisting of pre-galvanized steel enclosures painted black: high performance PICMG 3.0 backplane, power supply (DC); cooling system and AC/DC power components. Assembled, wired and tested prior to shipment.

## ORDERING INFORMATION

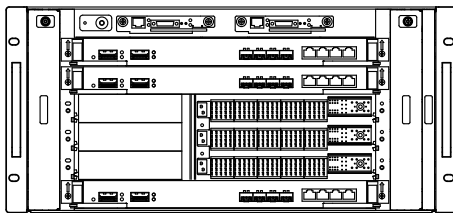

Description	Order Number
<ul style="list-style-type: none"> <li>■ 5UH x 19" W x 400mm D</li> <li>■ Holds 6, 8U x 280mm cards</li> <li>■ Holds 6, 8U x 80mm cards, rear I/O</li> <li>■ Redundant plug-in fan tray</li> <li>■ 6 slot replicated mesh backplane</li> <li>■ Provision for dual Shelf Manager (not installed)</li> <li>■ Dual 48VDC PEMs</li> </ul>	11A06FJB58Y4HMXX



## LINE DRAWINGS

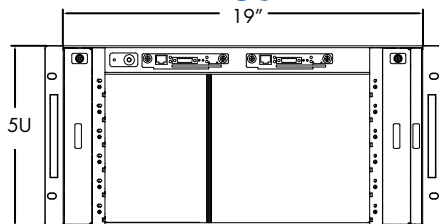

Front View

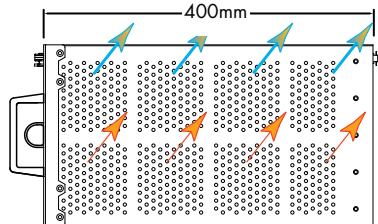

Air Flow - Side to Side

Side View

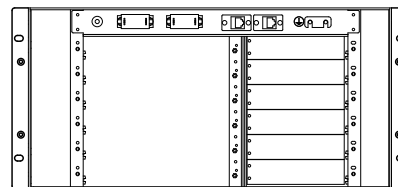

Rear View

## ENVIRONMENTAL

	Operating	Storage / Transit
<b>Temperature:</b>	0°C to +50°C	-20°C to +70°C
<b>Altitude:</b>	6000 ft. (1,829m)	50,000 ft. (15,240m)
<b>Humidity:</b>	5% to 95% Non condensing	5% to 95% Non condensing
<b>Shock:</b>	10 Gs @ 11ms	15 Gs @ 11ms (per ASTM 0775)
<b>Vibration:</b>	1.0 Gs @ 10 to 330 Hz	1.2 Gs @ 5 to 330 Hz
<b>Agencies:</b>	Designed to meet UL 1950, FCC Class A or B, CE	

## CUSTOM CONFIGURATIONS

11A      5 8 Y 4 H M X

NUMBER OF SLOTS BP  
00-21: Single BP; AY-YA: Split  
05 = 5 slot

BP BARE BOARD  
F = 2 x SM (Bussed IPMB)  
G = 2 x SM (Radial IPMB)  
Z = Custom

FABRIC ARCHITECTURE  
G = Dual Star  
H = Mesh  
J = Replicated Mesh  
Z = Custom

COOLING  
A = 1 x Tray (plug in)  
B = 2 x Tray (plug in)  
Z = Custom

HEIGHT  
5 = 5U

WIDTH  
8 = 84 T

REAR I/O  
N = No  
Y = Yes

DEPTH  
4 = 400 - 499mm

CARD ORIENTATION  
H = Horizontal

PSU INPUT  
C = 90 - 230VAC (Fixed)  
G = 90 - 230VAC (Plug-in)  
H = 48VDC  
M = Dual 48VDC  
P = 90-230VAC(2 x HS, N+1)  
X = No PSU

PSU OUTPUT  
(NOT ALL PSU COMBINATIONS AVAILABLE)  
2 = 200 - 299 watts  
3 = 300 - 399 watts  
4 = 400 - 499 watts  
5 = 500 - 599 watts  
6 = 600 - 699 watts  
8 = 800 - 899 watts  
A = 1000 - 1199 watts  
B = 1200 watt  
X = Not Installed

SHELF MANAGER (Installed)  
R = 1 x Fixed  
S = 1 x Plug in  
D = 2 x Plug in  
X = Not Installed

# AdvancedTCA, 6U - 19" Rackmount

## AC



### FEATURES:

- 6U high
- Holds 6 ATCA cards
- 6 slot replicated mesh backplane
- RTM (with cooling)
- Dual Shelf Managers
- Dual removable fan trays
- 250 watts/slot cooling
- 1200 watt, AC input PSU (N+1 optional)
- NEBS compliant removable air filter

### SCOPE OF SUPPLY

High quality 19" rackmount chassis platform consisting of pre-galvanized steel enclosures painted black: high performance PICMG 3.0 backplane, power supply, (AC) or PEM (DC); cooling system and AC/DC power components. Assembled, wired and tested prior to shipment.

### ORDERING INFORMATION

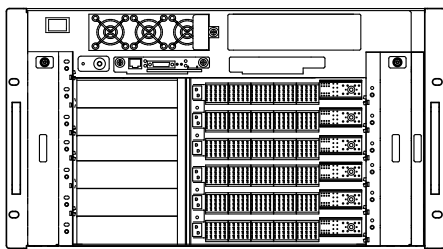

Description	Order Number
<ul style="list-style-type: none"> <li>■ 6 U H x 19" W x 400mm D</li> <li>■ Holds 6, 8U x 280mm blades</li> <li>■ Holds 6, 8U x 80mm cards, rear I/O</li> <li>■ Redundant plug-in fan tray</li> <li>■ 6 slot replicated mesh backplane</li> <li>■ Provision for dual Shelf Manager (not installed)</li> <li>■ 1 x 1200w, AC input PSU, (N+1 optional)</li> </ul>	<p>11A06FJB68Y4HGBX</p>

## LINE DRAWINGS

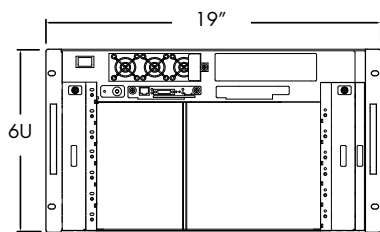

Front View

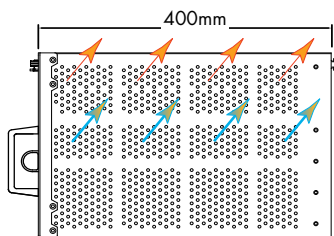

Side View  
Air Flow - Side to Side

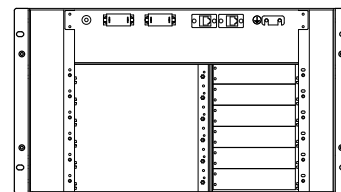

Rear View

## ENVIRONMENTAL

	Operating	Storage / Transit
<b>Temperature:</b>	0°C to +50°C	-20°C to +70°C
<b>Altitude:</b>	6000 ft. (1,829m)	50,000 ft. (15,240m)
<b>Humidity:</b>	5% to 95% Non condensing	5% to 95% Non condensing
<b>Shock:</b>	10 Gs @ 11ms	15 Gs @ 11ms (per ASTM 0775)
<b>Vibration:</b>	1.0 Gs @ 10 to 330 Hz	1.2 Gs @ 5 to 330 Hz
<b>Agencies:</b>	Designed to meet UL 1950, FCC Class A or B, CE	

## CUSTOM CONFIGURATIONS

11A       6 8 Y 4 H  B

- NUMBER OF SLOTS BP
  - 00-21: Single BP; AY-YA: Split
  - 02 = 2 slot
  - 05 = 5 slot
  - 06 = 6 slot
  - 14 = 14 slot

- BP BARE BOARD
  - E = 1 x SM
  - F = 2 x SM (Bussed IPMB)
  - G = 2 x SM (Radial IPMB)
  - Z = Custom

- FABRIC ARCHITECTURE
  - F = Star
  - G = Dual Star
  - H = Mesh
  - J = Replicated Mesh
  - Z = Custom

- COOLING
  - A = 1 x Tray (plug in)
  - B = 2 x Tray (plug in)
  - C = 3 x Tray (Plug in)
  - Z = Custom

- HEIGHT
  - 1 = 1U
  - 2 = 2U
  - 4 = 4U
  - 5 = 5U
  - C = 12U
  - D = 13U

- WIDTH
  - 8 = 84 T
  - E = ETSI

- REAR I/O
  - N = No
  - Y = Yes

- DEPTH
  - 4 = 400 - 499mm

- CARD ORIENTATION
  - V = Vertical
  - H = Horizontal

- PSU INPUT
  - C = 90 - 230VAC (Fixed)
  - G = 90 - 230VAC (Plug-in)
  - H = 48VDC
  - M = Dual 48VDC
  - N = Quad 48VDC
  - P = 90-230VAC(2 x HS, N+1)
  - Q = 90-230VAC(3 x HS, N+1)
  - X = No PSU

- PSU OUTPUT  
(NOT ALL PSU COMBINATIONS AVAILABLE)
  - 2 = 200 - 299 watts
  - 3 = 300 - 399 watts
  - 4 = 400 - 499 watts
  - 5 = 500 - 599 watts
  - 6 = 600 - 699 watts
  - 8 = 800 - 899 watts
  - A = 1000 - 1199 watts
  - B = 1200 - 1299 watts
  - C = 1600 - 1799 watts
  - D = 1800 - 1999 watts
  - E = 2000 - 2199 watts
  - F = 2200 - 2399 watts
  - G = 2400 - 2599 watts
  - H = 2600 - 2799 watts
  - X = Not Installed

- SHELF MANAGER (Installed)
  - R = 1 x Fixed
  - S = 1 x Plug in
  - D = 2 x Plug in
  - X = Not Installed

\*NOTE: Elma's radial IPMB signals are radially connected across the backplane to the Shelf ManagerCarrier Card. The Shmm 500 IPM module resides on the carrier card where these connections are bussed.

# AdvancedTCA, 13U - 19" Rackmount DC



## FEATURES:

- 13U high
- Holds 14 ATCA blades
- 14 slot dual star or full mesh backplane
- RTM (with 40 way slot cooling)
- Dual Shelf Managers
- Quad redundant 48VDC input
- 3 x removable fan trays
- 300 watts/slot cooling
- NEBS compliant removable air filter

## SCOPE OF SUPPLY

High quality 19" rackmount chassis platform consisting of pre-galvanized steel enclosures painted black: high performance PICMG 3.0 backplane, dual PEM (DC); cooling system and DC power components. Assembled, wired and tested prior to shipment.

## ORDERING INFORMATION

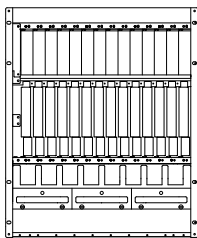

Description	Order Number
<ul style="list-style-type: none"> <li>■ 13 U H x 19" W x 400mm D</li> <li>■ Holds 14, 8U x 280mm blades</li> <li>■ Holds 14, 8U x 80mm cards, rear I/O</li> <li>■ 3 x removable fan trays</li> <li>■ 14 slot dual star backplane</li> <li>■ Provision for dual Shelf Manager (not installed)</li> <li>■ Quad 48VDC PEMs</li> </ul>	11A14FGCD8Y4VNXX

## LINE DRAWINGS

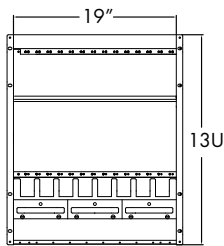

Front View

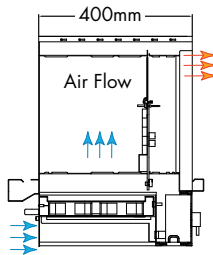

Side View

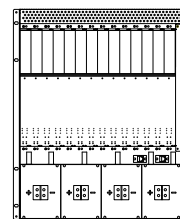

Rear View

## ENVIRONMENTAL

	Operating	Storage / Transit
<b>Temperature:</b>	0°C to +50°C	-20°C to +70°C
<b>Altitude:</b>	6000 ft. (1,829m)	50,000 ft. (15,240m)
<b>Humidity:</b>	5% to 95% Non condensing	5% to 95% Non condensing
<b>Shock:</b>	10 Gs @ 11ms	15 Gs @ 11ms (per ASTM 0775)
<b>Vibration:</b>	1.0 Gs @ 10 to 330 Hz	1.2 Gs @ 5 to 330 Hz
<b>Agencies:</b>	Designed to meet UL 1950, FCC Class A or B, CE	

## CUSTOM CONFIGURATIONS



- NUMBER OF SLOTS BP
  - 00-21: Single BP; AY-YA: Split
  - 02 = 2 slot
  - 05 = 5 slot
  - 06 = 6 slot
  - 14 = 14 slot
- BP BARE BOARD
  - E = 1 x SM
  - F = 2 x SM (Bussed IPMB)
  - G = 2 x SM (Radial IPMB)
  - Z = Custom
- FABRIC ARCHITECTURE
  - F = Star
  - G = Dual Star
  - H = Mesh
  - J = Replicated Mesh
  - Z = Custom
- COOLING
  - A = 1 x Tray (plug in)
  - B = 2 x Tray (plug in)
  - C = 3 x Tray (Plug in)
  - Z = Custom
- HEIGHT
  - 1 = 1U
  - 2 = 2U
  - 4 = 4U
  - 5 = 5U
  - C = 12U
  - D = 13U
- WIDTH
  - 8 = 84 T
  - E = ETSI
- REAR I/O
  - N = No
  - Y = Yes
- DEPTH
  - 2 = 200 - 299mm
  - 3 = 300 - 399mm
  - 4 = 400 - 499mm
- CARD ORIENTATION
  - V = Vertical
  - H = Horizontal
- PSU INPUT
  - C = 90 - 230VAC (Fixed)
  - G = 90 - 230VAC (Plug-in)
  - H = 48VDC
  - M = Dual 48VDC
  - N = Quad 48VDC
  - P = 90-230VAC(2 x HS, N+1)
  - Q = 90-230VAC(3 x HS, N+1)
  - X = No PSU
- PSU OUTPUT  
(NOT ALL PSU COMBINATIONS AVAILABLE)
  - 2 = 200 - 299 watts
  - 3 = 300 - 399 watts
  - 4 = 400 - 499 watts
  - 5 = 500 - 599 watts
  - 6 = 600 - 699 watts
  - 8 = 800 - 899 watts
  - A = 1000 - 1199 watts
  - B = 1200 - 1299 watts
  - C = 1600 - 1799 watts
  - D = 1800 - 1999 watts
  - E = 2000 - 2199 watts
  - F = 2200 - 2399 watts
  - G = 2400 - 2599 watts
  - H = 2600 - 2799 watts
  - X = Not Installed
- SHELF MANAGER (Installed)
  - R = 1 x Fixed
  - S = 1 x Plug in
  - D = 2 x Plug in
  - X = Not Installed

\*NOTE: Elma's radial IPMB signals are radially connected across the backplane to the Shelf ManagerCarrier Card. The Shmm 500 IPM module resides on the carrier card where these connections are bussed.



## ECP - Embedded Computing Products



Elma's Embedded Computing Products, designed and marketed under the ACT/Technico brand, provides innovative solutions with best in class partner products, our own line of storage and I/O products, and over 100 man-years of system integration experience. We also provide ruggedized solutions to meet the most demanding environmental requirements. Certified to ISO 9001, the company supplies integrated embedded systems to companies in defense/aerospace, homeland security, semiconductor equipment, communications, energy, and transportation industries.

Elma Electronic is the premier electronic packaging expert and offers best in class embedded board level products and services. Experience enables us to provide you with the right embedded system platform for your program needs. To support this effort, we have a first-class offering of standards based products – single board computers, mass storage, networking, device drivers, and more. We take true COTS products, such as single board computers and PMCs, then enhance and qualify them to meet project requirements.

The next several pages offer a brief overview of the product categories and services available. Please visit our website or contact your sales representative for complete listings and further details.

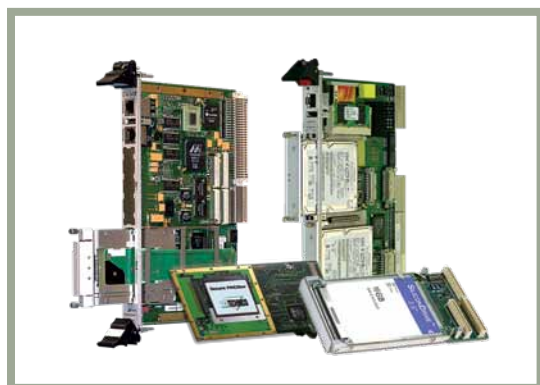

### STORAGE

#### Innovative Embedded Mass Storage Solutions

- Direct Attached Storage (DAS)
- Network Attached Storage (NAS) / RAID 0 - 5
- Removable drives / Hot Swap & FRU
- Data Security Solutions:
  - Secure-Erase
  - Write-Protect

#### DRIVE FORM FACTORS: 1.8", 2.5" & 3.5" & CF

- Rotating
- Solid state flash
- Optical (CD/DVD)
- Tape drives

#### BOARD FORM FACTORS:

- PMC/XMC/AMC
- CPCI, PICMG 2.16
- ATCA & MicroTCA

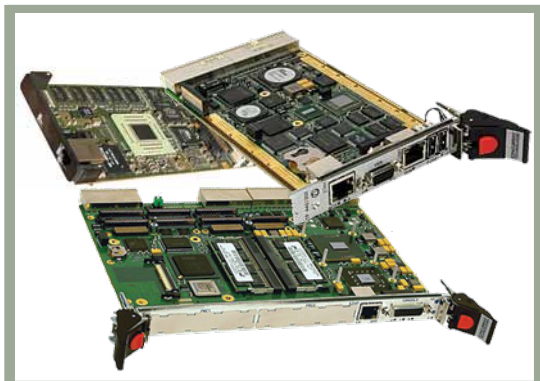

## SINGLE BOARD COMPUTERS & BLADES

From legacy to latest technologies

### PROCESSORS SUPPORTED:

- PowerPC
- PowerQUICC
- Intel architectures
- Single and multicore processors

### FORM FACTORS:

- CPCI, PICMG2.16
- ATCA, MicroTCA
- PrPMC/AMC

- COTS Ruggedization Program: Enhanced and/or modified standard products
- Extending board temperature ranges
- Conduction cooled



## NETWORKING

Full range of Ethernet solutions

### SWITCHES AND CONTROLLERS:

- Fast (10/100), Gigabit and 10 Gigabit Ethernet
- Up to 26 ports in a single slot
- Copper / Fiber (Optical)
- Layer 2 and full wire speed Layer 3
- IPv4 & IPv6
- Multicast / Unicast
- Standard, extended temp and conduction cooled versions

### BOARD FORM FACTORS:

- PMC/XMC
- CPCI, PICMG 2.16
- ATCA,  $\mu$ TCA

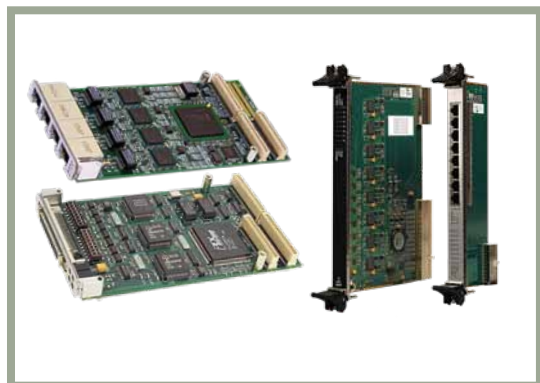

## I/O PRODUCTS

Wide range of available solutions

### FUNCTIONS:

- Audio and video
- Serial, parallel, binary
- Network Interface Controller (NICs)
- SCSI / ATA
- A/D and D/A channel converters
- 1553, ARINC
- Motion control, CANbus
- FPGA based

### FORM FACTORS:

- PMC / XMC / AMC
- 3U & 6U CPCI /PICMG 2.16

## ECP - Embedded Computing Products



### APPLIPAKS SBC AND I/O "BRICK"

#### Level Application Development Systems

The Elma AppliPak is a bundled, single procurement source. When you need to ensure that the Single Board Computer you order from us works with specific mezzanines, we can provide the SBC and the modules in a "brick" assembly. We'll bundle the boards under a single model number, qualify and test the assembly before shipment. A typical bundle includes a PowerPC or Intel SBC; Windows, Linux or VxWorks; boot file and drivers; choice of mass storage on PMC or 6U boards, and I/O options such as SCSI, Ethernet, digital I/O and audio. An AppliPak may also include Rear Transition Modules or Breakout Boards. The bricks are available in standard and rugged versions.

Elma can extend the environmental capabilities of your AppliPak with mechanical enhancements, temperature screening, and conformal coating. Each unit is fully tested and a full documentation package is available, including qualifications, manufacturing and test data.



### SYSTEMPAKS

#### Application Development System Platforms

This takes the AppliPak to the sub-system platform level by bundling the board set into a fully integrated and tested subsystem assembly, ready for application development. Available for all standard bus architectures, it is configured, tested and shipped in a chassis suitable for the environment in which it will be used.



## SUBSYSTEMS

### Integrated Sub-Systems

Our embedded sub-system solutions bring the bundle concept one step further, by providing the full range embedded package. They are designed to provide a complete platform upon which our customers build their integrated systems.

Typical systems might include powered chassis with SBC(s), mass storage, rear transition modules, audio and video modules, Ethernet or fabric switch(es), the operating system and any necessary drivers. We work with you to manage the project through it's entire life cycle.



## RUGGED PRODUCTS

### Standard COTS products enhanced for rugged environments

We can take true COTS products, such as single board computers and PMCs, then enhance and qualify them to meet project requirements. We offer a growing supply of conduction cooled boards as well as conformal coating for salt spray environments. We qualify boards and systems to the environmental standards of MIL STDs 810F, 901D and 167, and 461. We also design and prepare these products for barge testing.

We offer conformal coating per MIL STD I-46508 where required, and can extend the temperature range of COTS boards when needed.



## SERVICES

### Designed to fully support the total embedded solution

To support our efforts in providing you with the level of embedded solutions you require, we offer a full complement of services. A platform solution might include any or all of the following: design & build plans, procurement, full product documentation, test services and plans, manufacturing, software installation, project management such as inventory & spares maintenance.

We can do pcb and mechanical design, full doc package support, and testing services. We also offer OS configuration and install along with device drivers.

## Bridges - cPCI

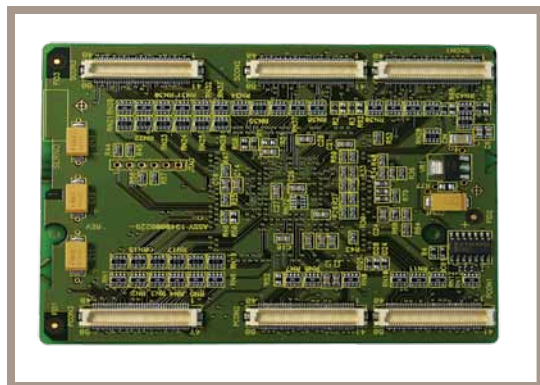

### MECHANICAL SPECIFICATIONS

- PCB: UL recognized 94V-0
- Vibration: According to DIN 41640 part 15: 10Hz to 500Hz 5g rms
- Impact: (10 impacts per axis x,y,z) 50g, 6ms
- Layers: 6 layers
- Connector: Six 0.050" pitch 2-row mezzanine connectors

### BOARD SPECIFICATIONS

- Layers: 6 layers
- PCB UL recognized 94V-0

### ELECTRICAL/OPERATING SPECIFICATIONS

- Clock frequency: 33 to 66 MHz
- Bus width: 32-bit, 64-bit
- Impedance Z<sub>0</sub> without connectors and daughter cards: 65Ωm +/-10%
- Possibility to use different VI/O voltage levels on primary and secondary back plane
- Onboard voltage regulator to supply 3.3V for the bridge driver
- JTAG interface according to IEEE1149.1

### FEATURES:

- Bridge module for the rear side of the backplane (plug-able)
- Low profile bridge enables the use of off-the-shelf rear transition modules
- Does not interfere with the use of the rP3, rP4 or rP5 connectors
- This transparent cPCI to cPCI bridge must be used with Elma Bustronic backplanes
- Based on the Pericom P17C8154 PCI to PCI Bridge
- Compatible with the Intel 21154BE/AC/AE/BE drivers
- Compatible with Intel P21150 drivers
- Provides superior performance in multiple bridge environments and more robust tolerance to 3.3/5v power start up sequence, lower latency and better thermal resistance
- Allows concurrent bus transfers on both PCI bus segments
- Supports 3.3V or 5V input for bridge driver (onboard voltage regulator)
- Provides 7 clock signals for the secondary backplane
- Arbitration for 7 devices on the secondary backplane possible
- Bus width: 32-bit, 64-bit
- 6-layer printed circuit board
- Automatic detection 32/64 bit systems
- Available for use by systems with system slot on left or right
- Bus frequency: 33MHz or 66MHz
- Dimensions of bridge module (4 slots wide):
  - PCB height 95.13 mm
  - PCB width 74.81 mm
  - PCB thickness 1.8 mm
- System configurations with one bridge: 7 slot (primary) + 3-7 slot (secondary) backplane
- System configurations with two bridges: 7 slots (primary) + 7 slot (middle) + 3-7 slot (tertiary) backplane. These configurations are for 33 MHz operation fewer slots supported with 66 MHz operation
- The cPCI bridges are a proprietary product and can only be used with specific Elma Bustronic and Elma Trenew designs. Contact Elma for more information.

## ORDERING INFORMATION

HEIGHT	WIDTH (mm)	THICKNESS (mm)	PART NUMBER
95.13	74.81	1.8mm	1940000260-000R (left)
95.13	74.81	1.8mm	1940000260-000R (right)



## Test Extender Boards - ATCA



### FEATURES: ATCA

- Mechanical extension of boards outside the chassis for testing
- Metal frame securely holds test board in place
- Designed to meet mechanical and electrical connection requirement of PICMG Rev. 3.0
- External ground planes for mechanical protection and EMI/RFI shielding
- The injector/ejector handles provide a secure and reliable connection to the chassis

### MECHANICAL SPECIFICATIONS

- 8U x 711.2mm

### BOARD SPECIFICATIONS

- 10-layer stripline design (cPCI)
- 2 oz. copper power and ground
- PCB UL recognized 94V-0
- PCB FR-4 or equivalent
- PCB .062" thick

## ORDERING INFORMATION

TYPE	HEIGHT	LENGTH	PART NUMBER
ATCA	8U	711.22mm	69-EXT-870-ATCA

## ATCA Probe Card



### SIGNAL INTEGRITY ENGINEERING & TESTING

Faster PCB designs are by nature more sophisticated and delicate. At higher clock speeds, the PCB demands cleaner signal transmission without compromising the stability of the system. This is where Signal Integrity engineering comes into play. Simply put, signal integrity studies the design of high-speed circuits that can accommodate cleaner signals passing through them. Cleaner signals, in turn, enable engineers to identify and minimize sources of distortion in data transmission, which could otherwise disrupt timing of the digital logic. Signal integrity issues such as reflections, cross talk, frequency dependent transmission line loss and dispersion can significantly lead to poorer system performance propagating through the interconnect. These SI issues arise from via, power/ground coupling, RLC effects in signal lines, etc. With 3.125 Gbps to 6.250 Gbps signal speeds across the backplane and beyond, an AdvancedTCA backplane is very susceptible to these types of issues.

## ORDERING INFORMATION

DESCRIPTION	PART NUMBER
Probe Card ATCA	69-PC-ATCA-XXXX

## Air Block Modules (Slot Bypass Board)

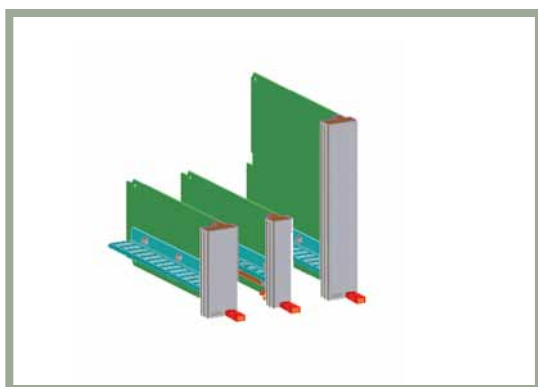

### DESCRIPTION

The slot bypass boards fill unused slot positions in the system enclosure. Elma's bypass boards block airflow whenever there were empty slots in your enclosure and ensure airflow is directed to the occupied slots where it is needed. Made of rigid construction, our bypass boards act as an effective barrier while maintaining the integrity of the enclosure's airflow system. Ejectors and injectors are optional and make these boards easy to remove when you need the slots for system expansion. Elma bypass boards are available in all VITA & PICMG sizes. Insulated boards are also available standard. Metal versions can be specially ordered. Bypass boards are supplied in assembled form only.

### FEATURES:

- Blocks airflow in unused slots
- Available for all Euro Card sizes (3U-9U, VITA & PICMG)
- Ejectors and Injectors available
- Plugs directly into empty slots
- Made of rigid construction
- Directs airflow properly for optimal system cooling

### AIR BLOCK MODULES

AMC air block modules can be used to fill empty slots in the card cage and re-direct airflow. The modules block the air from the inserted slot and force it to adjacent slots. This provides 10-50% of adjustable redirected airflow. The units come in single/mid, single/full or double/full sizes.

## ORDERING INFORMATION

CARD SIZE	ORDER NUMBER
3U x 160mm, 4HP	80-316JB-00
6U x 160mm, 4HP	80-616JB-00
6U x 220mm, 4HP	80-622JB-00
6U x 340mm, 4HP	80-634JB-00
9U x 400mm, 4HP	80-940JB-00

## Advanced TCA Backplanes - Mesh

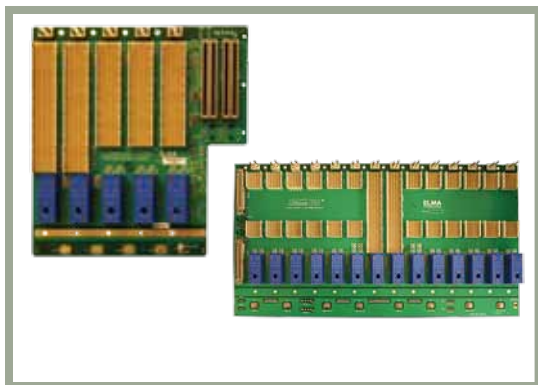

### FEATURES:

- Compliant to PICMG 3.0 Rev. 1.0 specification
- Gigabyte/Terabyte per second bandwidth per shelf
- Connections to IPM Sentry shelf manager
- Controlled impedance stripline design
- Dual star and 1X, 2X, 3X Mesh topologies are implementable)
- Optimized via signal integrity studies

### MECHANICAL SPECIFICATIONS

- Slots: 2, 5, 14, 16 (other sizes available)
- Height: approx. 5U typical, 1.2" pitch

### BOARD SPECIFICATIONS

- 18-layer board (5-slot Mesh)
- 2 oz. copper power and ground
- PCB UL recognized 94V-O
- PCB FR-4 or equivalent
- PCB .181" thick (5-slot Mesh), .171" (6-slot), .115" (2-slot)

### ELECTRICAL/OPERATING SPECIFICATIONS

- Conforms to: IEC 68/1:25/085/21
- Operating temperature: -40 C to +85 C
- Storage temperature: -55 C to 85 C
- Tx/Rx pair 100 Ohm +/- 10 %

## ORDERING INFORMATION

SLOTS	FABRIC SLOTS	NODE SLOTS	IPMB	FABRIC	PART NUMBER
2	All	All	Bussed	Rep Mesh	69-FJA02-502
5	All	All	Bussed	Rep Mesh	69-FJA05-506
6	All	All	Bussed	Rep Mesh	69-FJA06-50X
14	All	All	Bussed	Dual Star	69-FGA14-714

## ATCA MESH BACKPLANES - DESIGN ELEMENTS



Power Studs

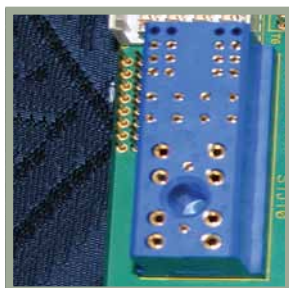

VBP Power Connector

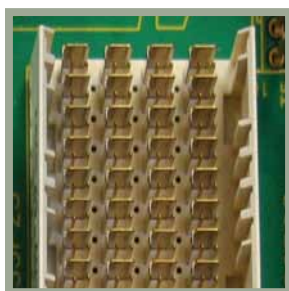

ZD Signal Connectors

### POWER DISTRIBUTION

The ATCA backplane family uses the Positronic VPB series, part number VPB30W8F9300A1. Adequate numbers of 48V 6/32 studs are distributed throughout the backplane.

### MATERIALS AND FINISHES - VPB

Insulator: Glass-filled polyester, UL 94V-0, blue color.

Contacts: Precision-machined copper alloy with gold flash over nickel plate.

### ELECTRICAL CHARACTERISTICS -VPB

Contact Current Ratings, per UL 1977 Size 16 Power

Contacts: 30 amperes continuous, all contacts under load.

Size 22 Signal Contacts: 2 amperes nominal rating.

Initial Contact Resistance;

Termination to termination:

Size 16 Contacts: 0.0022 ohms maximum,

Size 22 Contacts: 0.0085 ohms maximum, Per IEC 512-2, Test 2b.

Working Temperature: -55°C to +125°C.

### COMMON CONTACT POSITION FUNCTION - VPB

1-16 Low Speed Hardware Management

17-24 High Voltage Metallic Test and Ringing Generator Signals

25 Shelf Ground

26 Logic Ground

27/32 Enables for A and B power

28 A Return

29 B Return

30 A Early

31 B Early

33 A Voltage 34 B Voltage

### SIGNAL CONNECTORS

The ZD connector is designed to handle over 5 Gbps speeds over standard FR-4 PCB material. The design includes shielded differential pair signal pins for high-performance.

### OTHER CONNECTORS

#### SHELF MANAGEMENT CONNECTORS

Shmc1 connector goes to the Shmc port on slot 1. Shmc2 connector goes to the Shmc port on slot 2.

#### METAL AND RING CONNECTORS

MT1 and MT2 are TYCO 880222-4. It mates to an EI Series receptacle with crimp termination, such as 172142-4 There is also an MT EI Series with IDC termination.

#### RING CONNECTOR

The Ring connector is a Molex 71231-0005 which mates with the Molex 71694 and 5557 series.

## Components

### DEVICE HOLDERS (EMC Shielded)

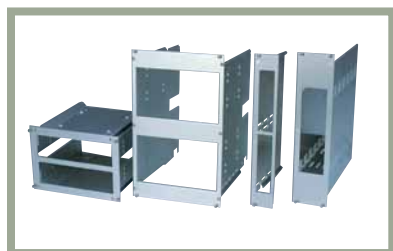

NUMBER OF DEVICES	LENGTH	ORDER NUMBER
1 x 3.5"	3U x 8HP	27C308-42
1 x 3.5"	4U x 8HP	27C408-41
2 x 3.5"	6U x 8HP	27C608-51
1 x 5.25" H.H.	6U x 12HP	27C612-11
1 x 5.25" H.H.	6U x 32HP	27C632-71
1 x 5.25" H.H.	4U x 12HP	27C412-11

### CARD GUIDE END FEET (offset 2.54mm)



COLOR	CARD DEPTH	1 PIECE	100 PIECES
Black	160mm	61-950-01	61-950-01-2
Red	160mm	61-950-03	61-950-03-2
Black	80mm	61-949-01	61-949-01-2

### CARD GUIDE END FEET (offset 2.54mm)



SIZE	POSITION	1 PAIR
1 x 3.5"	3U x 8HP	27C308-42

### EXTRUSIONS

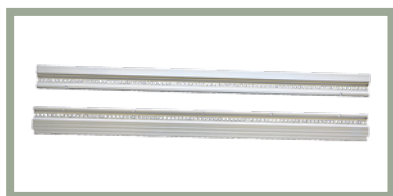

SIZE	1 PIECE
160mm	66-452-20
220mm	66-452-25
280mm	66-452-30
340mm	66-452-35



### ESD CLIPS (connecting printed board w/case)

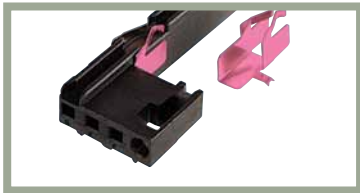

DESCRIPTION	1 PIECE	100 PIECES
ESD clip front bottom/rear top	63-863	63-864
ESD clip front top / rear bottom	63-865	63-866

### ESD SPRING (connecting ESD w/case)

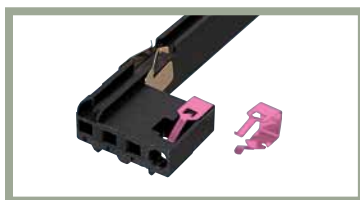

DESCRIPTION	1 PIECE	10 PIECES	100 PIECES
ESD Spring connecting	61-420	61-420-1	61-420-2

### CODING PINS



COLOR	1 PIECE	100 PIECES
gray	81-054-02	81-054-02-2
red	81-054-03	81-054-03-2

### MICROSWITCH

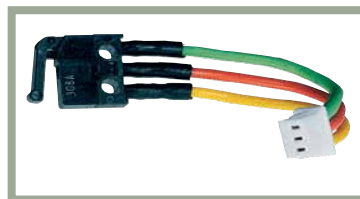

COLOR	1 PIECE	10 PIECES	100 PIECES
Black	81-088	81-088-1	81-088-2

# Components

## TELECOM HANDLES (standard)



COLOR	CARD DEPTH	1 PIECE	100 PIECES
Black	top	81-205	81-205-2
Black	bottom	81-206	81-206-2
Gray	top	81-207	81-207-2
Gray	bottom	81-208	81-208-2

## TELECOM HANDLES (offset 2.54mm)

COLOR	CARD DEPTH	1 PIECE	100 PIECES
Black	top	81-186	81-186-2
Black	bottom	81-187	81-187-2
Gray	top	81-188	81-188-2
Gray	bottom	81-189	81-189-2

## HOT-SWAP HANDLES (standard)

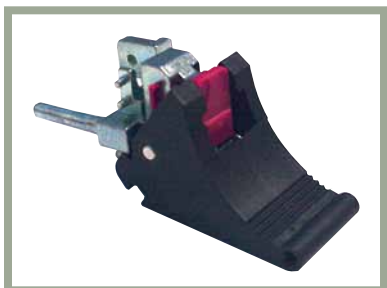

COLOR	CARD DEPTH	1 PIECE	100 PIECES
Black	top	81-095	81-095-2
Black	bottom	81-096	81-096-2
Gray	top	81-097	81-097-2
Gray	bottom	81-098	81-098-2

## HOT-SWAP HANDLES (offset 2.54mm)

COLOR	CARD DEPTH	1 PIECE	100 PIECES
Black	top	81-182	81-182-2
Black	bottom	81-183	81-183-2
Gray	top	81-184	81-184-2
Gray	bottom	81-185	81-185-2



### cPCI front panels, aluminum version 2.5mm front side anodized, rear conductive

HEIGHT	4HP	8HP	12HP
3U	66-544-23	66-548-23	66-552-23
6U	66-544-26	66-548-26	66-552-26

### Filler panels

COLOR	CARD DEPTH	1 PIECE	100 PIECES
4	66-544-83	-----	66-544-86
6	66-548-83	-----	66-548-86
12	66-552-83	-----	66-552-86
20	-----	21D420-50	-----
24	-----	21D424-50	-----
48	-----	-----	21D648-50
56	-----	-----	21D656-50
64	-----	-----	21D648-50

### Voltage I/O Jumper

COLOR	VOLTAGE	ORDER NUMBER
Red	5V	E800734
Violet	3.3V	E800735

### Voltage I/O coding keys

COLOR	VOLTAGE	ORDER NUMBER
Red	5V	E800734
Violet	3.3V	E800735

### System monitor

COLOR	ORDER NUMBER
3U	69-450-30
4U	69-450-40
6U	69-450-60

# LOCATIONS

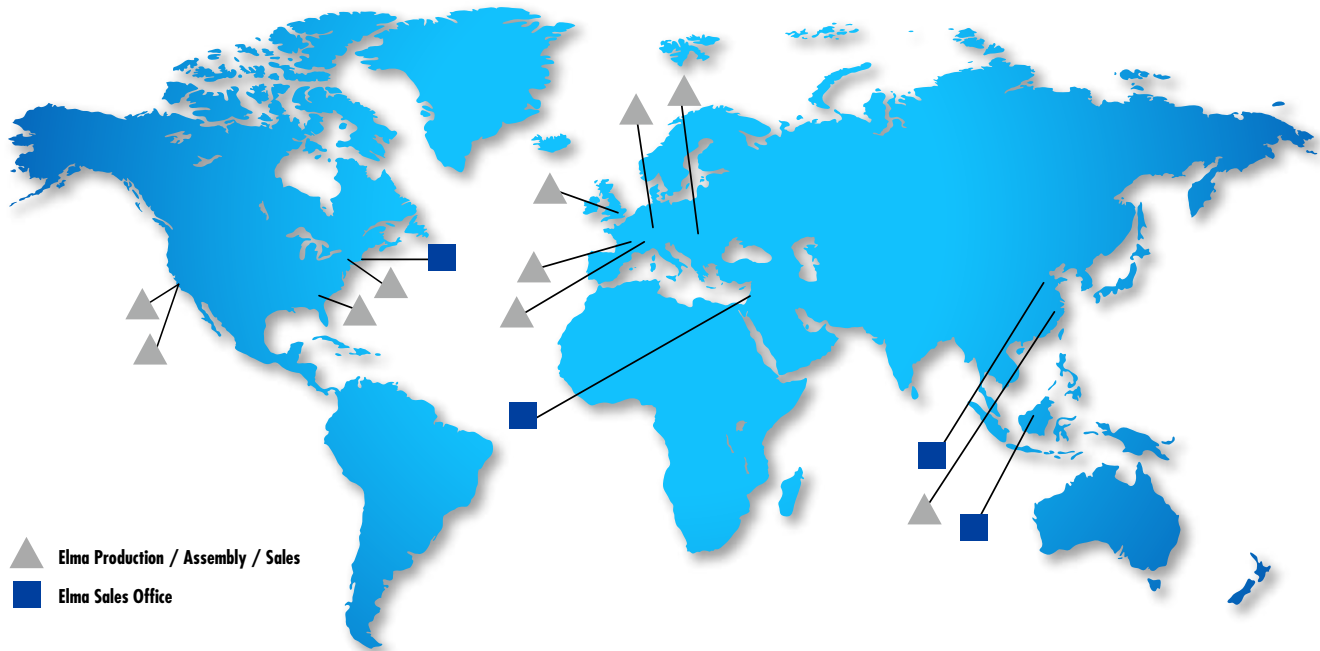

▲ Elma Production / Assembly / Sales  
 ■ Elma Sales Office

## ELMA ELECTRONIC/OPTIMA

Elma Electronic/Optima EPS  
 1775 MacLeod Drive  
 Lawrenceville, GA 30043  
 Phone: (770) 496-4000  
 Fax: (770) 496-4041  
 sales@optimaeps.com  
 www.optimaeps.com, & www.elma.com

## UNITED STATES, ELMA ELECTRONIC

Elma Electronic US Headquarters  
 44350 Grimmer Blvd.  
 Fremont, CA 94538  
 Phone: (510) 656-3400  
 Fax: (510) 656-3783  
 sales@elma.com  
 www.elma.com

Elma Electronic Inc.  
 760 Veterans Circle  
 Warminster, PA 18974  
 Phone: 215-956-1200  
 Fax: 215-956-1201  
 sales@acttechnico.com  
 www.acttechnico.com

## ELMA BUSTRONIC

Elma Bustronic Headquarters  
 44350 Grimmer Blvd.  
 Fremont, CA 94538  
 Phone: (510) 490-7388  
 Fax: (510) 490-1853  
 sales@elmabustronic.com  
 www.elmabustronic.com

## SWITZERLAND

Elma Electronic AG  
 Hofstrasse 93, Postfach  
 8620 Wetzikon  
 Phone: +41 44 933 41 11  
 Fax CH: +41 44 933 42 15  
 Fax Inter: +41 44 932 38 12  
 sales@elma.ch  
 www.elma.com

## CHINA

Elma Electronic China  
 8F, 355 Fu Te Road (West1)  
 Wai Gao Qiao Free Trade Zone  
 Pudong District, Shanghai 200131  
 Phone: +86 21 5866 5908  
 Fax: +86 21 5866 5918  
 sales@elmachina.com  
 www.elma.com

## ASIA PACIFIC

Elma Asia Pacific Pte. Ltd  
 115-A Commonwealth Drive  
 #03-14 Tanglin Halt Industrial Estate  
 Singapore 149596  
 Phone: +65 6479 8552  
 Fax: +65 6479 8662  
 sales.elmaap@elma.com  
 www.elma.com

## GERMANY

Elma Trenew Electronic GmbH  
 Stuttgarter Strasse 11  
 D-75179 Pforzheim  
 Phone: +49 7231 97 340  
 Fax: +49 7231 97 3497  
 info@elma.de  
 www.elma.com

## UNITED KINGDOM

Elma Electronic UK Ltd  
 Solutions House, Fraser Road  
 Priory Business Park  
 Bedford MK44 3BF  
 Phone: +44 (0)1234 838822  
 Fax: +44 (0)1234 836650  
 info@elma-mektron.co.uk  
 www.elma.com

## ISRAEL

Elma Electronic Israel Ltd.  
 34, Modi'in St.  
 IL.Z. Sgula  
 Petach-Tikva 49271  
 Phone: +972 3 930 50 25  
 Fax: +972 3 931 31 34  
 sales@elma.co.il  
 www.elma.com

## FRANCE

Elma Electronic France SASU  
 ZA du Buisson Rond  
 F-38460 Villemoirieu  
 Phone: +33 4 37 06 21 10  
 Fax: +33 4 37 06 21 19  
 sales@elma-electronic.fr  
 www.elma.com

## ROMANIA

Elma Electronic SRL  
 Maltopol Nr.16 Street, sector 1  
 RO-011048 Bucuresti  
 Phone +4021 310 7998  
 Fax +4021 310 7992  
 info@elma.ro  
 www.elma.com