

# 6U 5-Slot OpenVPX Backplane

## BKP6-CEN05-11.2.5-n

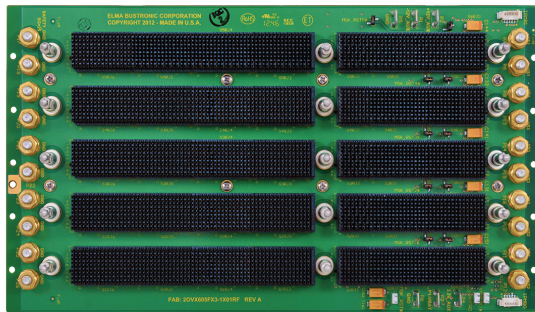

### Description

This 6U OpenVPX backplane features 5 slots in centralized and distributed topologies. The centralized version features a double Fat Pipe expansion plane and a dual star routing topology for the data plane. The distributed topologies offer 3.125 to 6.250 Gbauds/performance in one PCB.

Elma offers a variety of backplane topologies to support a wide range of system interconnect requirements. Our VPX backplanes are designed in accordance with the relevant Backplane Profile Descriptions provided within the current ANSI-VITA 46.0 and ANSI-VITA 65 standards.

### Features

- Compliant to ANSI/VITA 65-2102 and ANSI/VITA 46.0-2013
- High-Speed Velox connector
- Rugged Eurocard form factor in 6U height
- Provides built-in ESD ground protection in every slot
- Signal integrity analysis report available upon request

### Board Specifications

- 24 layer stripline design for 3.125 Gbaud version, 28 layers for 6.25 Gbaud version
- 1 oz. power and ground
- PCB FR-4 or equivalent for 3.125 Gbaud version, Nelco 4000-13EPSI for 6.25 Gbaud version
- PCB 0.212" thick

### Mechanical Specifications

- 6U height
- 5 slots
- Velox connectors

### Slot Profiles

- Slot 1 - 4: SLT6-1F1Q2U2T-10.2.1
- Slot 5: SLT6-SWH-16U20F-10.4.2

## Related Products and Applications

### Highly integrated applications such as:

- Integrated display processing, mission management and navigational control for avionics systems
- Industrial monitoring, medical equipment, and night-vision systems requiring enhanced graphics capabilities
- Shipboard systems for target tracking and high definition displays
- Applications requiring a mix of I/O options, high compute density and enhanced graphics

- Load boards convection or conduction cooled
- Rear Transition Modules for I/O
- Intel & Freescale Single Board Computers
- Blade level networking boards (Ethernet, PCI Express)
- Rackmount, desktop, and ATR chassis platforms
- Ruggedization programs

**VPX**

# 6U 5-Slot OpenVPX Backplane

## BKP6-CEN05-11.2.5-n



VPX



Backplanes

### Line Drawing

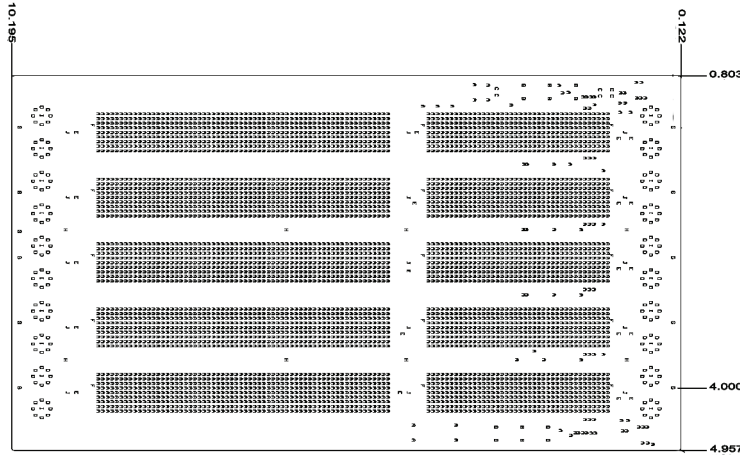

### Backplane Topology

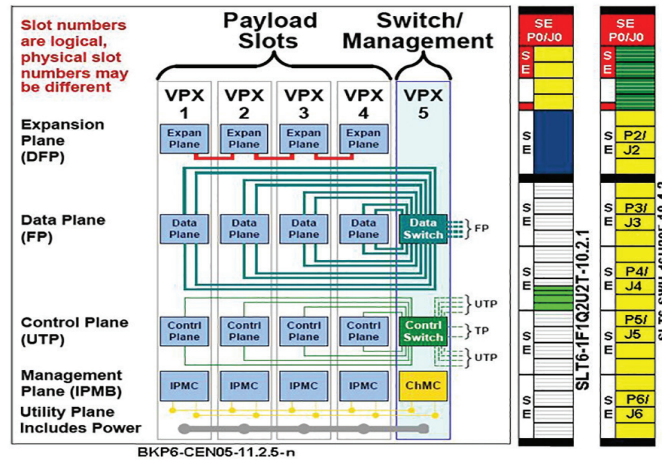

### Order Information

Height	Total Slots	Description	Profile Number	Part Number
6U	5	VPX centralized switch, channel Gbaud rate up to 3.125	BKP6-CEN05-11.2.5-1	1OVX605FX1-1X01R
6U	5	VPX centralized switch, channel Gbaud rate up to 3.125, no RTM connectors	BKP6-CEN05-11.2.5-1	1OVX605FX1-1X00R
6U	5	VPX centralized switch, channel Gbaud rate up to 6.25Gbps	BKP6-CEN05-11.2.5-3	1OVX605FX3-1X01R

Please contact our sales for more details.

China:	+86 21 5866 5908	Germany:	+49 7231 97 34 0	Singapore:	+65 6479 8552	United Kingdom:	+44 1234 838 822
France:	+33 437 06 21 10	Israel:	+972 3 930 50 25	Switzerland:	+41 44 933 41 11	United States:	+1 510 656 3400

For other countries, please visit our website.