

Module Handles/Panels

- Ergonomic design, grooves for easy handling
- Compliant to latest AMC/MicroTCA specifications
- Die cast construction for robust performance
- Positive detent at three distinct positions
- Fits all current microswitch locations
- Custom designs and colors available
- Additional space for customer logo on top
- Logo integrated in die-cast is possible
- Extruded panel has improved aesthetics
- Machined or stamped panel cut-outs, tight radiuses

Elma offers standard and customized MicroTCA handles and front panels. With Elma's superior quality and precision milling, even the toughest of tolerances can be achieved. Other services include logo integration, silk screening, overlays, custom cut-outs and more.

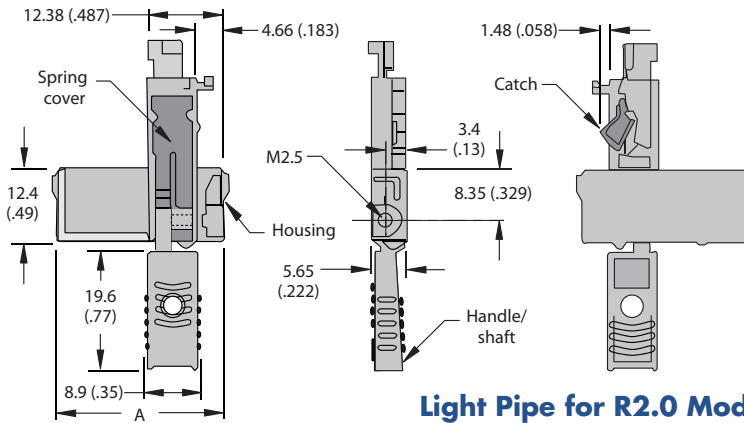

Light Pipe for R2.0 Module Handle

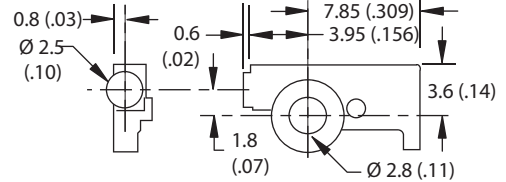

Panel Preparation Module Handles

All panel preparation tolerances $\pm 0.1 (.004)$

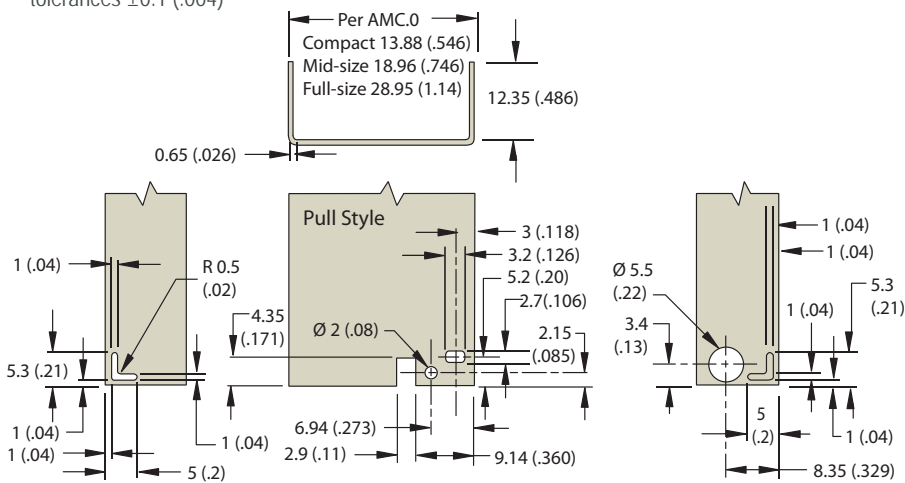

Printed Circuit Board Component Side

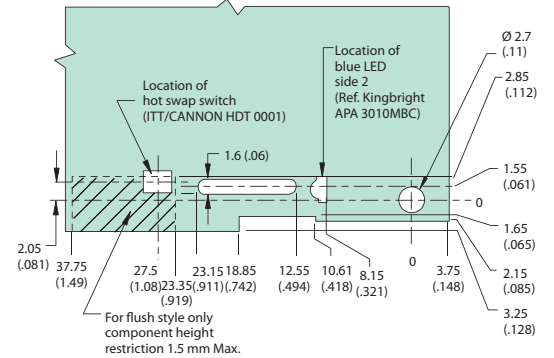

Panel Preparation Light Pipe Brackets

Printed Circuit Board Component Side 1

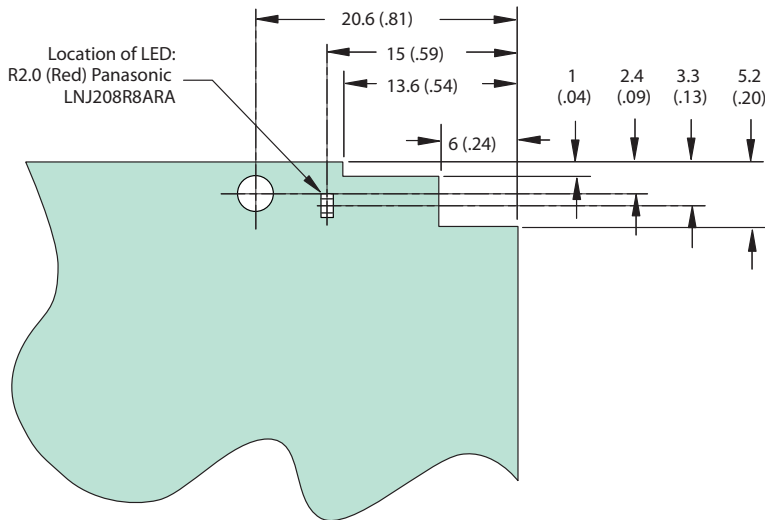

Printed Circuit Board Component Side 2

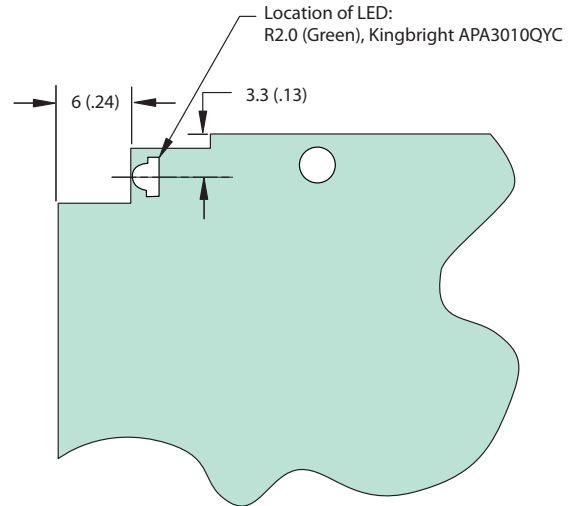

Installation

Installation Notes

1. Snap handle assembly and light pipe bracket into faceplate.
2. For R2.0, position blue LED light pipe into handle assembly and faceplate. Light pipe should be positioned against outside wall of handle assembly.
3. Slide PCB in place and secure with screws. Blue LED light pipe is located on component side 2 of the PCB.

Notes

All panel preparation tolerances ± 0.1 (.004)

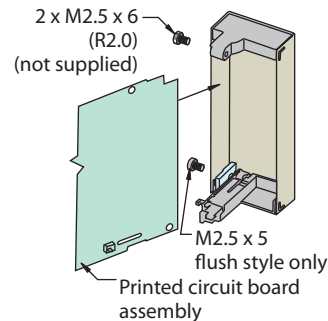
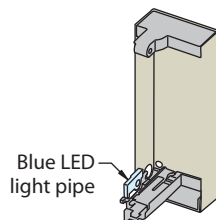
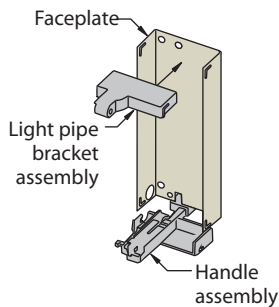

Operation

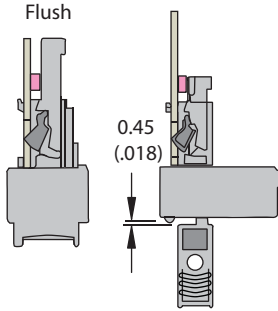

Module Latched
Switch Actuated

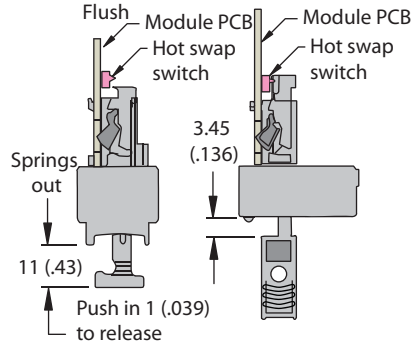

Module Latched
Switch Released

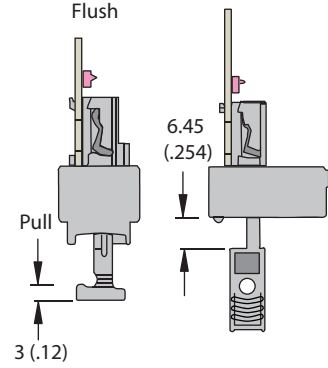

Module Unlatched
Switch Released

Order Information

Model Number	Description
CAE023555	AMC Handle Module, Mid Size 4HP
CAE019780	AMC Handle Module, Full Size 6HP
CAE023887	AMC Light Pipe for Handle Module
CAE027492	AMC Top Module with 2 LED Light Pipe, Mid Size 4HP
CAE027493	AMC Top Module with 2 LED Light Pipe, Full Size 6HP