

# 7: Assembly Material and Other Accessories

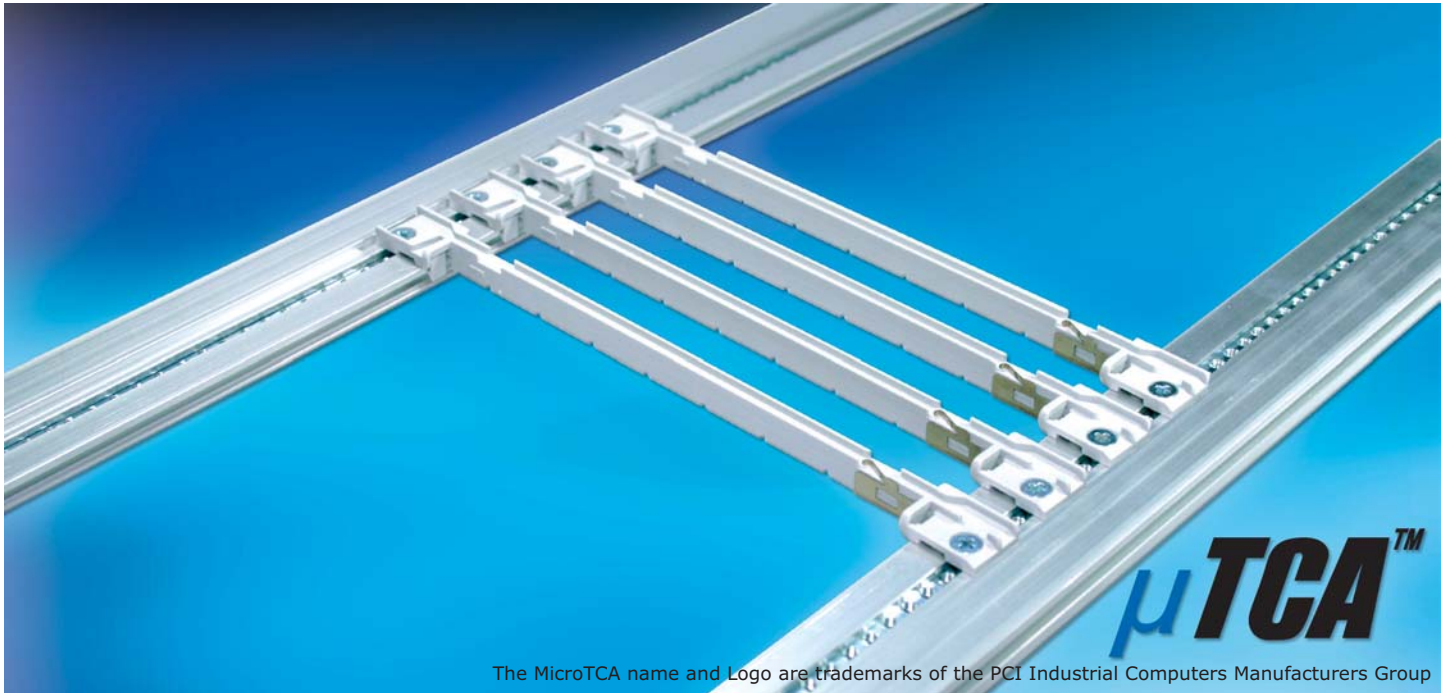

The MicroTCA name and Logo are trademarks of the PCI Industrial Computers Manufacturers Group

## uTCA

- The PICMG® Micro Telecommunications Computing Architecture (MicroTCA™) specification defines the requirements for a system that uses PICMG Advanced Mezzanine Cards (AdvancedMCs) directly on a Backplane. This specification, MicroTCA.0, defines the general mechanical, electrical, thermal, and management properties of a MicroTCA Shelf necessary to support AMC.0-compliant Modules.
- MicroTCA has a primary purpose of serving as a platform for telecommunications and enterprise computer network equipment. Its secondary goal is to function as a platform for other demanding marketplaces, such as Customer Premises Equipment (CPE).
- MicroTCA is complementary to the PICMG3.0 Advances Telecommunications Computing Architecture (AdvancedTCA or PICMG3). Where AdvancedTCA is optimized for very high capacity, high performance applications, MicroTCA is designed to address cost sensitive and physically smaller applications with lower capacity, performance, and perhaps less stringent availability requirements. MicroTCA preserves many of the important philosophies of AdvancedTCA, including basic interconnect topologies and management structure

## 7.6 uTCA Components

- Made to build uTCA card cages
- Conform to the PICMG specification MTCA.0 R1.0
- Prepared to meet EMC requirements



### 7.6.1 uTCA Extrusion

- Aluminium clear passivated
- Special length or surface treatments on request

Description	Part-No.
uTCA Extrusion L=443.32 mm	66-242-443
uTCA Extrusion L=428.08 mm	66-242-428

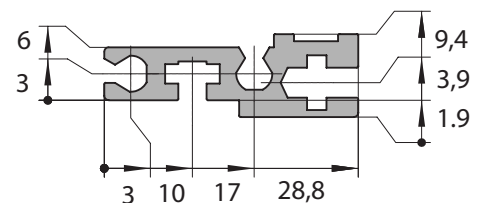
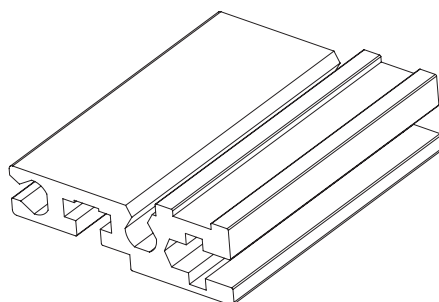

# 7: Assembly Material and Other Accessories



## 7.6.2 uTCA Card Guide

- Fits on extrusion 66-242-X
- Top and bottom use of card guide
- Plastic, grey, UL94 V-0
- ESD clip can be assembled at front and rear

Description	Part-No. 10 pcs.	Part-No. 100 pcs.
uTCA Card guide	61-193-00-1	61-193-00-2



## 7.6.3 uTCA ESD Clip

- Fits on uTCA card guide 61-193-00
- Stainless steel

Description	Part-No. 10 pcs.	Part-No. 100 pcs.
uTCA ESD clip	61-194-1	61-194-2



## 7.6.4 Tapped Strips M3

- 2 x 6 mm M3
- Fit into uTCA extrusion 66-242-XX
- Steel, galvanised, passivated

Description	Part-No.
Tapped strips 2 x 6 mm M3, L= 443.02 mm	61-242-443
Tapped strips 2 x 6 mm M3, L= 427.78 mm	61-242-428



## 7.6.5 Countersunk screw M3 x 6 mm

- Cross recessed, Philips #1
- Steel, galvanised, passivated

Description	Part-No. 1 pc.	Part-No. 100 pcs.
Counter sunk screw M3 x 6mm	5332-06	1906-12