

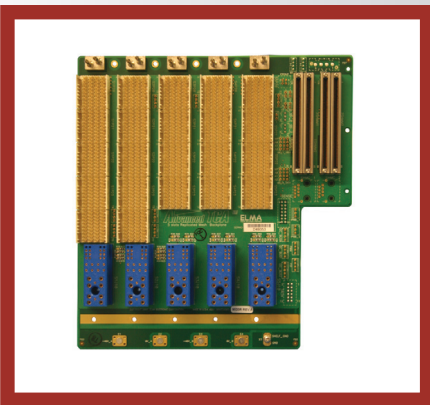

FEATURES

- 19" rack mount, fully compliant to PICMG 3.0
- 5U H x 444mm W x 385mm D
- Rugged steel Construction
- Fits into Zone 4 Seismic Rack (NEBS 3)
- 5 slot full mesh backplane connectivity
- Single or dual 700W AC input PSU providing 48V @ 15A
- Dual fan trays on each side of the card cage
- Side-to-side cooling in push-pull configuration, redundant cooling
- Single or dual pluggable ATCA Shelf manager optional

This 5U AdvancedTCA Chassis features full redundancy with dual redundant fan trays, shelf managers, and A/C power supplies. The shelf managers and A/C power is optional. Side-to-side cooling is achieved via a plug-in fan tray with dual 170 CFM fans with PWM (pulse width modulation) control on each side of the card cage. The redundant push/pull configurations of the fans offer higher levels of reliability. The new N+1 version offers two 700W or 1200W power supplies as well as optional dual shelf management integration. The chassis is ideal for designs that need the high-performance and functionality of ATCA, but prefer power supply options.



ATCA 5-SLOT REPLICATED MESH BACKPLANE

- According to ATCA spec PICMG 3.0
- Pluggable shelf manager
- Dual Star or standard Full Mesh implementable
- Replicated Mesh topology
- Gigabyte/Terabyte per second bandwidth per shelf
- Connections for IPM Sentry Shelf Manager plugging
- Signal integrity optimized via simulation/characterization studies

AdvancedTCA 5U SYSTEM W/ REDUNDANT COOLING

Line Drawings

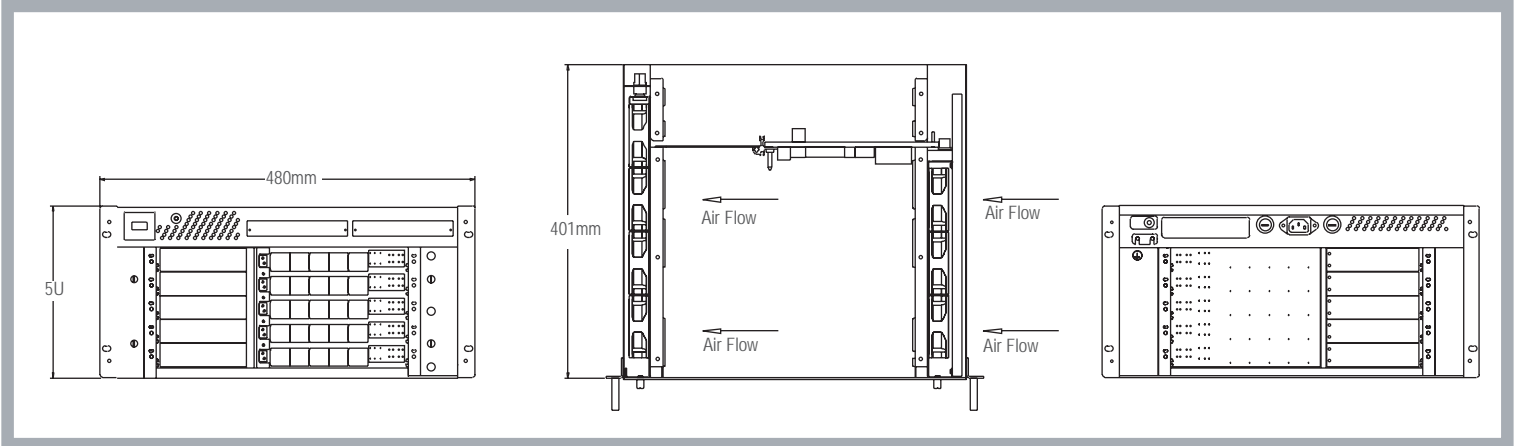

Environmental Specifications

	Operating	Storage/Transit
Temperature:	0°C to +50°C	-20°C to +70°C
Altitude:	6000 ft. (1,829m)	50,000 ft. (15,240m)
Humidity:	5% to 95% Non condensing	5% to 95% Non condensing
Shock:	10 G's @ 11ms	15 G's @ 11ms (per ASTM 0775)
Vibration:	1.0 G's @ 10 to 330 Hz	1.2 G's @ 5 to 330 Hz
Agencies:	Designed to meet UL 1950, FCC, A, B, CE	

Order Information

Description	Model Number
AdvancedTCA 19" rackmount chassis <ul style="list-style-type: none"> • 5UH x 84HP W x 400mm D • Holds 5, 8U x 280mm Cards • Redundant plug-in fan trays • 5 Slot Replicated Mesh backplane • Dual 48V DC input • Shelf Manager not installed • 1st Gen shelf mgr w/2mm HM connectors 	11A05GJB58Y3HCBX
AdvancedTCA 19" rackmount chassis <ul style="list-style-type: none"> • 1200W AC plug-in PSU • Holds 5, 8U x 280mm Cards • Redundant plug-in fan trays • 5 Slot Replicated Mesh backplane • Dual 48V DC input • 1x Shelf Manager (2nd Gen), not installed • 2nd Gen shelf mgr w/MicroTCA.0 connectors 	11A05HJB58Y4HGBX
AdvancedTCA 19" rackmount chassis <ul style="list-style-type: none"> • Dual 1200W AC plug-in PSUs • Holds 5, 8U x 280mm Cards • Redundant plug-in fan trays • 5 Slot Replicated Mesh backplane • Dual 48V DC input • 2x Shelf Manager (2nd Gen), not installed • 2nd Gen shelf mgr w/MicroTCA.0 connectors 	11A05GJB58Y4HPGX
ATCA 5-slot Replicated Mesh Backplane <ul style="list-style-type: none"> • Compliant to PICMG 3.0 Rev. 1.0 specification • 3 x Replicated Mesh topology • Connections to IPM Sentry shelf manager • 18-layer stripline design • Optimized via signal integrity studies 	69-RM505-ZD

AdvancedTCA 5U W/REDUNDANT COOLING SYSTEM

- Custom Configurations

11A 1 2 3 4 5 6 7 8 9 10 11 12 13

1,2) Num. of Slots BP

00-21: Single BP AY-YA: Split
• 05 = 5 slot

3) BP Bare board

- E = 1 x SM
- F = 2 x SM (Bussed IPMB)
- G = 2 x SM (Radial IPMB)*
- H = 1 x SM (Radial IPMB*)
- Z = Custom

4) Fabric Architecture

- G = Dual Star
- H = Mesh
- J = Replicated Mesh
- Z = Custom

5) Cooling

- A = 1 x Tray (plug in)
- B = 2 x Tray (plug in)
- Z = Custom

6) Height

- 5 = 5U

7) Width

- 8 = 84T

8) Rear I/O

- N = No
- Y = Yes

9) Depth

- 4 = 400mm-499mm

10) Card Orientation

- H = Horizontal

11) PSU Input

- C = 90-230VAC (Fixed)
- G = 90-230VAC (Plug In)
- H = 48VDC
- M = Dual 48VDC
- P = 90-230VAC(2 x HS, N+1)
- Q = 90-230VAC(3 x HS, N+1)
- X = No PSU

12) PSU Output (Note: Not all PSU combinations available)

- 4 = 400-599 watt
- 6 = 600-799 watt
- 8 = 800-999 watt
- A = 1000-1199 watt
- B = 1200 watt
- C = 1600-1799 watt
- D = 1800-1999 watt
- E = 2000-2199 watt
- F = 2200-2399 watt
- G = 2400-2599 watt
- H = 2600-2799 watt
- X = Not installed

13) Shelf Manager (Installed)

- S = 1 x Plug in
- D = 2 x Plug in
- X = Not installed

* Elma's radial IPMB signals are radially connected across the backplane to the Shelf Manager Carrier Card. The Shmm 500 IPM module resides on the carrier card where these connections are bussed.